

## MODEL ITMA DC - INTELLIGENT THERMOCOUPLE MODULE WITH ANALOG OUTPUT



- **USER PROGRAMMABLE INPUT**  
(Thermocouple types J, K, T, & E, or millivolt)
- **MICROPROCESSOR CONTROLLED**
- **SIMPLE ADJUSTABLE RANGE SETTING** (Using Input Signal)
- **THERMOCOUPLE BREAK DETECTION**
- **MOUNTS ON "T" AND "G" STYLE DIN RAILS**
- **3-WAY ELECTRICAL ISOLATION** (POWER/INPUT/OUTPUT)
- **MULTIPLE ANALOG OUTPUTS** (0 to 20 mA, 4 to 20 mA, and 0 to 10 VDC)
- **WIDE OPERATING TEMPERATURE RANGE** (-25°C to 75°C)
- **POWER & MEMORY ERROR INDICATION**
- **9 to 32 VDC POWERED**



### DESCRIPTION

The ITMA accepts a thermocouple or millivolt input and converts it into a voltage or current output. The voltage or current output is linearly proportional to the temperature or millivolt input. This output is ideal for interfacing to indicators, chart recorders, controllers, or other instrumentation equipment.

The ITMA is DC powered. The DC power input is isolated from the signal input and analog output. The unit scales the analog output proportionally to the thermocouple or millivolt input signal. The analog output may be configured for one of the following: 0 to 20 mA, 4 to 20 mA, or 0 to 10 VDC. Making the signal conversion with the ITMA to a current output signal, makes the signal less susceptible to noise interference and allows accurate transmission over long distances. The 3-Way isolation allows the use of grounded thermocouples which can provide additional noise reduction benefits.

The ITMA uses a ten position DIP switch to accomplish the input sensor configuration, range selection, and unit calibration. A simple range setting technique (Field Calibration) is used so the actual input signal adjusts the output for scaling. This technique eliminates the need for potentiometers which are vulnerable to changes due to vibration.

The unit is equipped with a universal mounting foot for attachment to standard DIN style mounting rails, including top hat rail (T) according to EN 50 022 - 35 x 7.5 and 35 x 15, and (G) profile according to EN 50 035 - G 32.

### SAFETY SUMMARY

All safety related regulations, local codes and instructions that appear in the manual or on equipment must be observed to ensure personal safety and to prevent damage to either the instrument or equipment connected to it. If equipment is used in a manner not specified by the manufacturer, the protection provided by the equipment may be impaired.



CAUTION: Read complete instructions prior to installation and operation of the unit.

### SPECIFICATIONS

1. **POWER:** 9 to 32 VDC; 1.75 W The power supply must have 300 mA for 200 msec. surge capacity.
2. **INPUT:** J, K, T, E, mV [selectable via DIP switch]
3. **OUTPUT:** All output signals scaled linearly using temperature or mV input. Unit is shipped set for 4 to 20 mA output. 4 to 20 mA or 0 to 20 mA selected via internal jumper.
  - Voltage Output Compliance:**
    - 0 to 10 VDC across min 1 KΩ load (10 mA)
    - 20 mV peak to peak max. ripple (for frequencies up to 120 Hz)
  - Current Output Compliance:**
    - 0 to 20 mA through max. 600Ω load (12 VDC)
    - 4 to 20 mA through max. 600Ω load (12 VDC)
    - 15 mV peak to peak max. ripple across 600Ω load (for freq. up to 120 Hz)
4. **TC BREAK DETECTION:** Nominal values shown in the following order: (0 to 20 mA, 4 to 20 mA, and 0 to 10 VDC).
  - Upscale:** 22.9 mA, 22.5 mA, and 11.5 VDC
  - Downscale:** -0.5 mA, 3.5 mA, and -0.4 VDC
5. **RESPONSE TIME:** 400 msec (to within 99% of final value w/step input; typically, response is limited to response time of probe.)
6. **TEMPERATURE EFFECTS:**
  - Temperature Coefficient:** ± 0.025% of input range per °C
  - Ice Point Compensation:** ± 0.75°C for a 50°C change in temperature
7. **DIELECTRIC WITHSTAND VOLTAGE:** 1500 VAC for 1 minute  
**Working Voltage:** 50 VAC  
 Power input to Signal input, Power input to Signal output, & Signal input to Signal output.
8. **RANGE & ACCURACY:** (12 Bit resolution)  
**Accuracy:** ± ( 0.075% Range + 0.25°C [Conformity] + 0.50°C [Ice Point]) at 23°C after 20 min. warm-up, conforming to ITS-90.  
 Note: TC Conformity and Ice Point do not apply to mV input

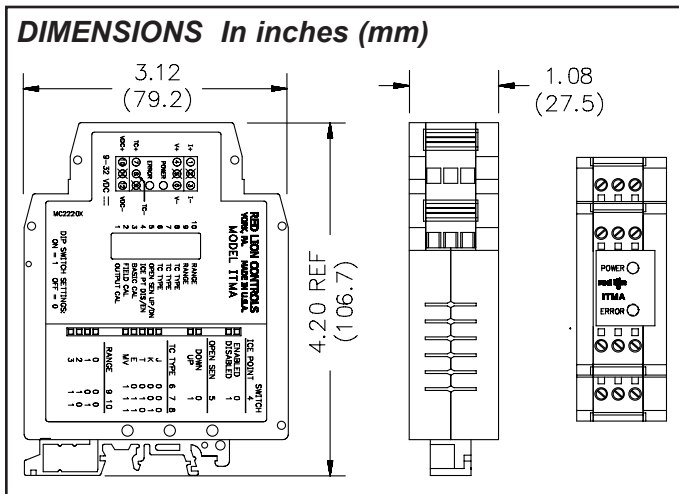

**Relative Humidity:** Less than 85% RH (non-condensing)

**Span:** The input span can be set to a min. of 1/8 of the full scale range, anywhere within that range.

**Thermocouple Accuracy for each type and the corresponding ranges:**

TC (INPUT)	RANGE	DIP SWITCH TYPE RANGE 6 7 8 9 10	TEMPERATURE & mV RANGE	RANGE ACCURACY	WIRE COLOR	
					ANSI	BS1843
J	0	0 0 0 0 0	-136 to 111°C	± 0.19°C	White (+) Red (-)	Yellow (+) Blue (-)
	1	0 0 0 0 1	69 to 575°C	± 0.38°C		
	2	0 0 0 1 0	338 to 800°C	± 0.35°C		
	3	0 0 0 1 1	-149 to 862°C	± 0.76°C		
K	0	0 0 1 0 0	-200 to 541°C	± 0.56°C	Yellow (+) Red (-)	Brown (+) Blue (-)
	1	0 0 1 0 1	427 to 1132°C	± 0.53°C		
	2	0 0 1 1 0	648 to 1372°C	± 0.54°C		
	3	0 0 1 1 1	-192 to 1372°C	± 1.17°C		
T	0	0 1 0 0 0	-225 to 149°C	± 0.28°C	Blue (+) Red (-)	White (+) Blue (-)
	1	0 1 0 0 1	74 to 326°C	± 0.19°C		
	2	0 1 0 1 0	68 to 400°C	± 0.25°C		
	3	0 1 0 1 1	-200 to 400°C	± 0.45°C		
E	0	0 1 1 0 0	-111 to 311°C	± 0.32°C	Violet (+) Red (-)	Brown (+) Blue (-)
	1	0 1 1 0 1	276 to 609°C	± 0.25°C		
	2	0 1 1 1 0	377 to 1000°C	± 0.47°C		
	3	0 1 1 1 1	-114 to 1000°C	± 0.84°C		
mV	0	1 1 1 0 0	-9 to 6 mV	± 0.0113 mV	N/A	N/A
	1	1 1 1 0 1	-9 to 22 mV	± 0.0233 mV		
	2	1 1 1 1 0	-9 to 63 mV	± 0.0540 mV		
	3	1 1 1 1 1	-9 to 77 mV	± 0.0645 mV		

Note: DIP switch settings ON = 1 OFF = 0

**Accuracy Example:**  
Type "J" Range "0"  
-136°C to 111°C

Range	Conformity	Ice Point	Total Error
(±0.19°C +	±0.25°C	+ ±0.50°C)	= ±0.94°C

**9. ENVIRONMENTAL CONDITIONS:**

- Operating Temperature Range:** -25°C to 75°C (-13°F to 167°F)
- Storage Temperature Range:** -40 to 85°C (-40°F to 185°F)
- Operating and Storage Humidity:** 85% max. relative humidity (non-condensing) from -25°C to 75°C.
- Altitude:** Up to 2000 meters

- 10. MOUNTING:** Universal mounting foot for attachment to standard DIN style mounting rails, including top hat (T) profile rail according to EN50022 -35 x 7.5 and -35 x 15, and G profile rail according to EN50035 - G32.
- 11. CONNECTION:** Compression type terminal block
- 12. CONSTRUCTION:** High impact black plastic case
- 13. CERTIFICATIONS AND COMPLIANCES:**

**SAFETY**

IEC 1010-1, EN 61010-1: Safety requirements for electrical equipment for measurement, control, and laboratory use, Part 1.

**ELECTROMAGNETIC COMPATIBILITY**

**Immunity to EN 50082-2**

Electrostatic discharge	EN 61000-4-2	Level 2; 4 Kv contact <sup>1</sup> Level 3; 8 Kv air
Electromagnetic RF fields	EN 61000-4-3	Level 3; 10 V/m <sup>2</sup> 80 MHz - 1 GHz
Fast transients (burst)	EN 61000-4-4	Level 4; 2 Kv I/O Level 3; 2 Kv power
RF conducted interference	EN 61000-4-6	Level 3; 10 V/rms 150 KHz - 80 MHz

**Emission to EN 50081-2**

RF interference	EN 55011	Enclosure class B
-----------------	----------	-------------------

**Notes:**

- This device was designed for installation in an enclosure. To avoid electrostatic discharge, precautions should be taken when the device is mounted outside an enclosure. When working in an enclosure (ex. making adjustments, setting switches etc.) typical anti-static precautions should be observed before touching the unit.
- Self-recoverable loss of performance during EMI disturbance at 10 V/m: Process signal may deviate during EMI disturbance.

For operation without loss of performance:

Unit is mounted in a metal enclosure (Buckeye SM7013-0 or equivalent) I/O and power cables are routed in metal conduit connected to earth ground.

Refer to the EMC Installation Guidelines section of this bulletin for additional information.

- 14. WEIGHT:** 4.02 oz. (114.0 g)

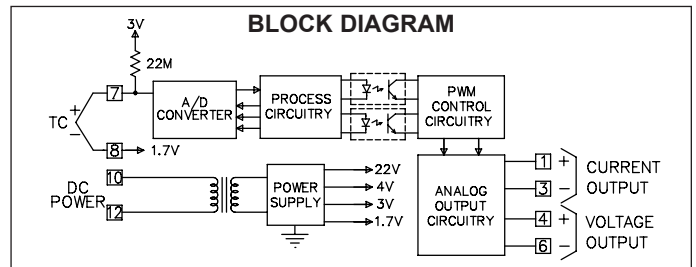

**FUNCTION DESCRIPTIONS**

**Open Sensor Detection**

The output can be set to go Upscale or Downscale for the detection of an open sensor. The nominal values for each output range are listed under TC Break Detection in the Specifications section. This setting is always active, so changes to the setting are effective immediately.

**Ice Point Compensation**

The Ice Point Compensation for the thermocouple sensors can be enabled (DIP Switch OFF) or disabled (DIP Switch ON). The mV sensor input is not affected by this setting. Generally, the Ice Point Compensation is always enabled.

**Unit Malfunction**

If the unit has scaling problems (output remains at -0.5 mA, 3.5 mA, or -0.5 VDC nominal), check the ERROR LED on the front of the unit. An E<sup>2</sup>PROM problem is indicated when the ERROR LED is on. If the ERROR LED is on, perform a Basic Calibration followed by a Field Calibration. Turn the power off for 5 seconds. Turn power on and check if the ERROR LED is on. If the LED is on, contact the factory.

**EMC INSTALLATION GUIDELINES**

Although this unit is designed with a high degree of immunity to ElectroMagnetic Interference (EMI), proper installation and wiring methods must be followed to ensure compatibility in each application. The type of the electrical noise, source or coupling method into the unit may be different for various installations. Cable length, routing and shield termination are very important and can mean the difference between a successful or a troublesome installation. Listed below are some EMC guidelines for successful installation in an industrial environment.

- Use shielded (screened) cables for all Signal and Control inputs. The shield (screen) pigtail connection should be made as short as possible. The connection point for the shield depends somewhat upon the application. Listed below are the recommended methods of connecting the shield, in order of their effectiveness.
  - Connect the shield only at the rail where the unit is mounted to earth ground (protective earth).
  - Connect the shield to earth ground at both ends of the cable, usually when the noise source frequency is above 1 MHz.
  - Connect the shield to common of the unit and leave the other end of the shield unconnected and insulated from earth ground.
- Never run Signal or Control cables in the same conduit or raceway with AC power lines, conductors feeding motors, solenoids, SCR controls, and heaters, etc. The cables should be run in metal conduit that is properly grounded. This is especially useful in applications where cable runs are long and portable two-way radios are used in close proximity or if the installation is near a commercial radio transmitter.
- Signal or Control cables within an enclosure should be routed as far away as possible from contactors, control relays, transformers, and other noisy components.
- In extremely high EMI environments, the use of external EMI suppression devices, such as ferrite suppression cores, is effective. Install them on Signal and Control cables as close to the unit as possible. Loop the cable through the core several times or use multiple cores on each cable for additional protection. Install line filters on the power input cable to the unit to suppress power line interference. Install them near the power entry point of the enclosure. The following EMI suppression devices (or equivalent) are recommended:
  - Ferrite Suppression Cores for signal and control cables:
    - Fair-Rite # 0443167251 (RLC #FCOR0000)
    - TDK # ZCAT3035-1330A
    - Steward #28B2029-0A0
  - Line Filters for input power cables:
    - Schaffner # FN610-1/07 (RLC #LFIL0000)
    - Schaffner # FN670-1.8/07
    - Corcom #1VR3

**Note:** Reference manufacturer's instructions when installing a line filter.
- Long cable runs are more susceptible to EMI pickup than short cable runs. Therefore, keep cable runs as short as possible.

## WIRING CONNECTIONS

All conductors should meet voltage and current ratings for each terminal. Also, cabling should conform to appropriate standards of good installation, local codes and regulations. It is recommended that power supplied to the unit be protected by a fuse or circuit breaker. When wiring the unit, use the numbers on the label to identify the position number with the proper function. Strip the wire, leaving approximately 1/4" (6 mm) of bare wire exposed (stranded wire should be tinned with solder). Insert the wire into the terminal, and tighten the screw until the wire is clamped tightly.

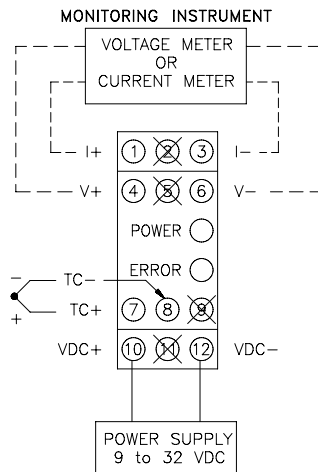

## INPUT, OUTPUT, AND POWER CONNECTIONS

### INPUT

Ensure thermocouple wire ends are stripped and clean. Connect positive thermocouple lead to terminal #7 (TC+). Connect negative thermocouple lead to terminal #8 (TC-). If the thermocouple probe cannot be connected directly to the module, thermocouple wire or thermocouple extension-grade wire must be used to extend the connection (copper wire does not work). Always refer to the thermocouple manufacturer's recommendations for: mounting, temperature range, shielding, etc.

Remove this side of the unit case.

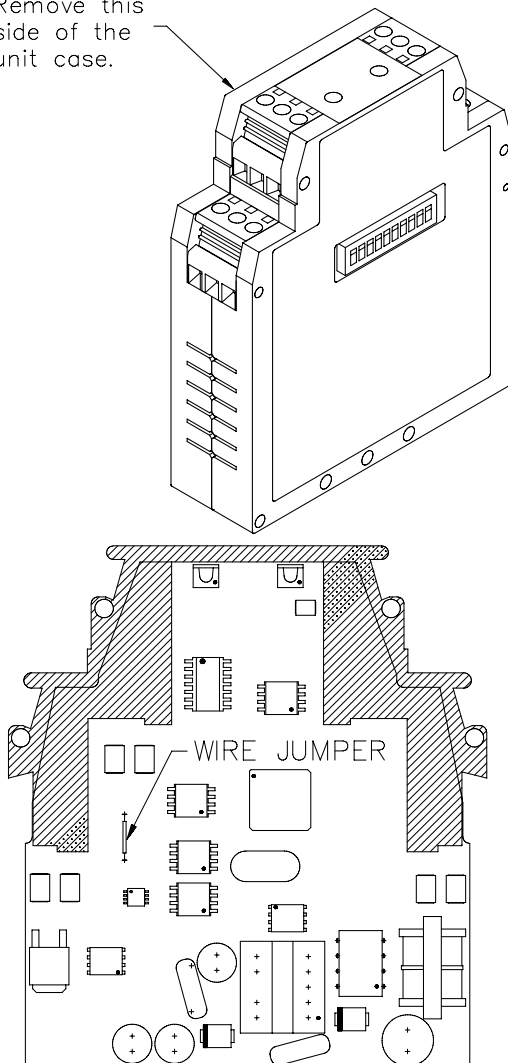

### OUTPUT

Connect the output signal wires to the desired output terminals. For voltage output, use terminals #4 and #6; for current output, use terminals #1 and #3 observing proper polarity. Only one output may be used at a time. The unit is factory set for a 4 to 20 mA output. The voltage output will track the current output nominally within a  $\pm 2.5\%$  deviation range.

To select 0 to 20 mA, output you must open the case and cut the wire jumper. The jumper is located to the left side of the board as shown in the drawing.

### POWER

Connect DC power to terminals #10 and #12 observing proper polarity. Be certain DC power is within the 9 to 32 VDC specifications.

### POWER LED

The ITMA has a green LED located on the front to indicate that power is applied to the unit.

### DIP SWITCH SETTING DESCRIPTIONS

SWITCH	LABEL	DESCRIPTION
1	OUTPUT CAL	Output Calibration
2	FIELD CAL	Field Calibration
3	BASIC CAL	Basic Calibration
4	ICE PT DIS/EN	Ice Point Compensation - Disabled (ON) / Enabled (OFF)
5	OPEN SEN UP/DN	Open Sensor Detection - Upscale (ON) / Downscale (OFF)
6	TC TYPE	Thermocouple Type - 3 switch combination setting
7		
8		
9	RANGE	Sensor Range - 2 switch combination setting
10		

### TC Type and Range switch settings (ON = 1 OFF = 0)

TC TYPE	DIP SWITCH		
	6	7	8
J	0	0	0
K	0	0	1
T	0	1	0
E	0	1	1
mV	1	1	1

RANGE	DIP SWITCH	
	9	10
0	0	0
1	0	1
2	1	0
3	1	1

### FACTORY SETTINGS

The unit is shipped from the factory calibrated for a 4 to 20 mA output using a type J thermocouple in range 3. The ITMA should be Field calibrated by the operator for the application environment it will be used in. If the unit is not recalibrated by the operator, the following table lists the temperature ranges for the given thermocouple types.

NOMINAL FACTORY FIELD CALIBRATION		
TYPE	RANGE	TEMPERATURE RANGE
J	3	-50°C to 500°C
K	3	-85°C to 790°C
T	3	-195°C to 162°C
E	3	3°C to 602°C

### TROUBLESHOOTING

For further technical assistance, contact technical support at the appropriate company numbers listed.

# CALIBRATION PROCEDURES

## 1.0 Field Calibration

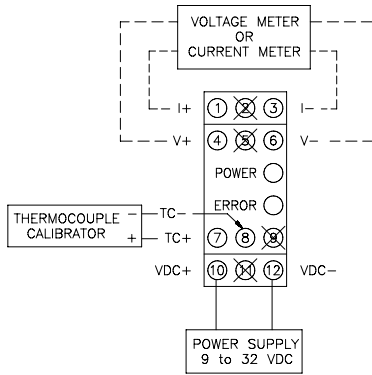

Field Calibration Wiring

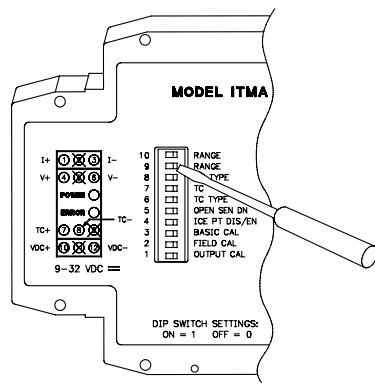

Note: The nominal output value for the various output ranges are designated in the following order: (0 to 20 mA, 4 to 20 mA, 0 to 10 VDC)

Allow a 30 minute warm-up period before starting Field Calibration. Field Calibration scales the voltage or current output to a temperature or mV input. This procedure assigns an input value to analog output low and an input value to analog output high. The microprocessor handles configuring the output so it is linear to the temperature or mV input. The Field Calibration procedure is described below.

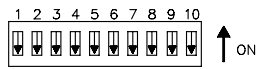

Step 1.3 & 1.4



Step 1.5



Step 1.7

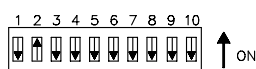

Step 1.9



Step 1.11



Step 1.13

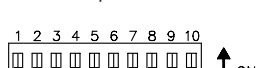

Step 1.14

Note: The unit needs to have the Field Calibration completed by the operator before normal operation. To abort this calibration and reset to the previous settings, set the FIELD CAL switch(#2) OFF prior to the final OFF setting of the OUTPUT CAL switch (Step 1.13) and turn off power. Wait 5 seconds and then turn on power and the previous settings will be loaded.

### Field Calibration with a Thermocouple Calibrator

- 1.1 Enable the Ice Point Compensation on the Thermocouple Calibrator and set it to the Thermocouple type being used in your application.
- 1.2 Connect the thermocouple wire as selected in step 1 to the TC input terminals of the ITMA and the thermocouple calibrator.
- 1.3 Set the ICE PT EN/DIS switch (#4) OFF to enable Ice Point Compensation.
- 1.4 Set the Type and Range for the thermocouple or mV used in your application (DIP switches #6 through #10). (TC type "J", Range 0 shown)
- 1.5 Set the FIELD CAL switch (#2) ON. [Output goes to -0.8 mA, 3.5 mA, or -0.4 V nominal]
- 1.6 Apply the input signal for the analog output low value.
- 1.7 Set the OUTPUT CAL switch (#1) ON. [Output stays at -0.8 mA, 3.5 mA, or -0.4 V nominal]
- 1.8 Adjust the input signal up until the output equals desired low value.
- 1.9 Set the OUTPUT CAL switch (#1) OFF. [Output increases to 22.9 mA, 22.5 mA, or 11.5 V nominal]
- 1.10 Apply the input signal for the analog output high value.
- 1.11 Set the OUTPUT CAL switch (#1) ON. [Output decreases to 21.1 mA, 20.7 mA, or 10.6 V nominal]
- 1.12 Adjust the input signal down until the output equals desired high value.
- 1.13 Set the OUTPUT CAL switch (#1) OFF.
- 1.14 Set the FIELD CAL switch (#2) OFF.
- 1.15 Disconnect the thermocouple calibrator from the ITMA and connect the actual sensor to be used in the application.

## 2.0 Field Calibration With an Accurate Adjustable Millivolt Source: (Alternate Method)

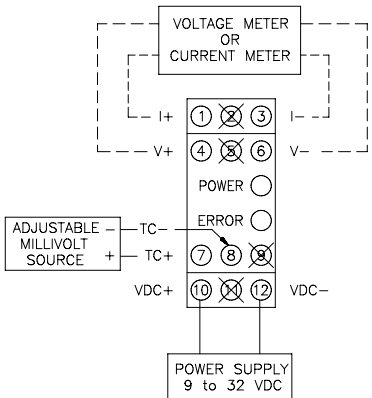

Field Calibration Wiring

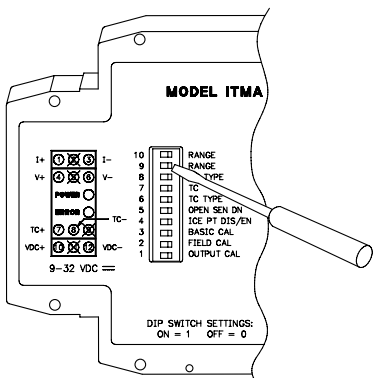

Step 2.2 & 2.3

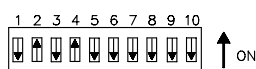

Step 2.4

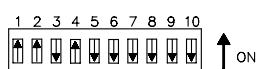

Step 2.6



Step 2.8



Step 2.10



Step 2.12



Step 2.13



Step 2.14

Note: The nominal output value for the various output ranges are designated in the following order: (0 to 20 mA, 4 to 20 mA, 0 to 10 VDC)

This calibration procedure can be used to assign the high and low input values if a thermocouple calibrator is not available.

Note: To abort this calibration and reset to the previous settings, set the FIELD CAL switch(#2) OFF prior to the final OFF setting of the OUTPUT CAL switch (Step 2.12) and turn off power. Wait 5 seconds and then turn on power and the previous settings will be loaded.

- 2.1 Connect the accurate Adjustable Millivolt Source to the TC input terminals.
- 2.2 Set the ICE PT EN/DIS switch (#4) ON to disable Ice Point Compensation.
- 2.3 Set the Type and Range for the thermocouple or mV used in your application (DIP switches #6 through #10). (TC type "J", Range 0 shown)
- 2.4 Set the FIELD CAL switch (#2) ON. [Output goes to -0.8 mA, 3.5 mA, or -0.4 V nominal]
- 2.5 Apply the input signal (mV equivalent for the thermocouple temperature) for the analog output low value.
- 2.6 Set the OUTPUT CAL switch (#1) ON. [Output stays at -0.8 mA, 3.5 mA, or -0.4 V nominal]
- 2.7 Adjust the input signal up until the output equals desired low value.
- 2.8 Set the OUTPUT CAL switch (#1) OFF. [Output increases to 22.9 mA, 22.5 mA, or 11.5 V nominal]
- 2.9 Apply the input signal (millivolt equivalent for the thermocouple temperature) for the analog output high value.
- 2.10 Set the OUTPUT CAL switch (#1) ON. [Output decreases to 21.1 mA, 20.7 mA, or 10.6 V nominal]
- 2.11 Adjust the input signal down until the output equals desired high value.
- 2.12 Set the OUTPUT CAL switch (#1) OFF.
- 2.13 Set the FIELD CAL switch (#2) OFF.
- 2.14 Set the ICE PT EN/DIS switch (#4) OFF to enable Ice Point Compensation.
- 2.15 Disconnect millivolt source from the ITMA and connect the actual sensor to be used in the application.

### 3.0 Ice Point Calibration

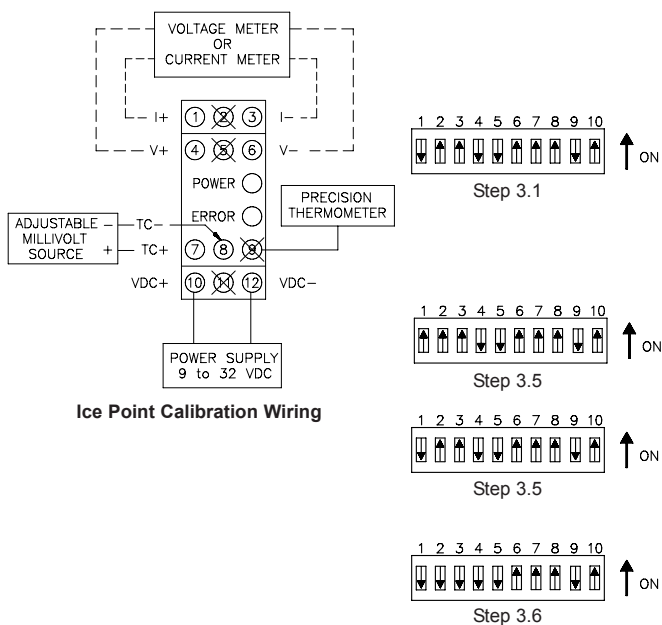

Note: The nominal output value for the various output ranges are designated in the following order: (0 to 20 mA, 4 to 20 mA, 0 to 10 VDC)

The Ice Point Calibration should only be performed with an ambient temperature between 21°C and 29°C. This Calibration was performed on the unit at the factory during the Basic Calibration and generally does not need to be done again. The Ice Point Compensation can be adjusted through this calibration. The Ice Point Calibration procedure is described below.

Note: Calibration can be aborted by setting the BASIC CAL switch(#3) OFF prior to the setting of the OUTPUT CAL switch OFF. (Step 3.6)

- 3.1 Connect a precision mV source with an accuracy of 0.02% to Terminal #7 TC+ Input and Terminal #8 TC- Input. Set the OUTPUT CAL switch (#1) and ICE PT EN/DIS switch (#4) OFF. Set the BASIC CAL (#3) and FIELD CAL (#2) switches ON. The positions of switches #5 thru #10 are not relevant for this calibration procedure.
- 3.2 Connect a precision thermometer (accuracy of 0.1°C) to the unused terminal (#9) beside the TC Input terminals.
- 3.3 Apply power and allow a 30 minute warm-up period. [Output goes to -0.9 mA, 3.4 mA, or -0.5V nominal]
- 3.4 Using the temperature indicated by the precision thermometer, input an equivalent 1 mV/°C signal to the TC Input terminals and wait 5 seconds.
- 3.5 Set the OUTPUT CAL switch (#1) ON and then OFF.
- 3.6 Set the BASIC CAL switch (#3) and FIELD CAL switch (#2) OFF. [Output increases to -0.8 mA, 3.5 mA, or -0.38 V nominal, or more]

### 4.0 Basic Calibration

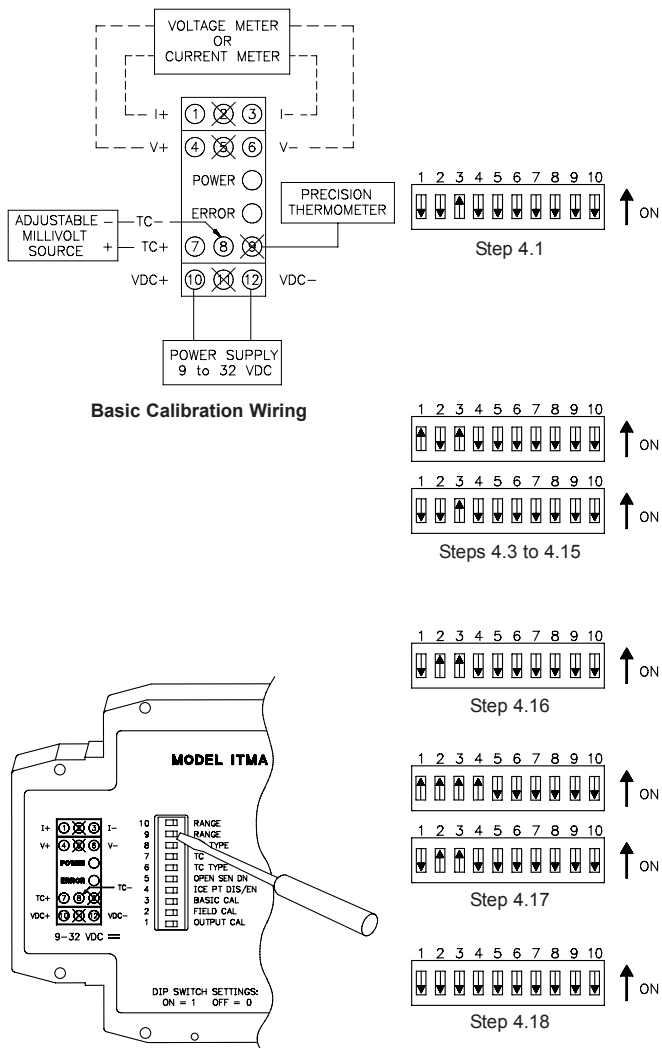

Note: The nominal output value for the various output ranges are designated in the following order: (0 to 20 mA, 4 to 20 mA, 0 to 10 VDC)

The Basic Calibration should only be performed with an ambient temperature between 21°C and 29°C. The Basic Calibration was performed on the unit at the factory and generally does not need to be done again. This procedure initializes the unit by calibrating the input, and the Ice Point Compensation. The Basic Calibration should be performed only if a condition exists as described in the "Unit Malfunction" section. After completion of this calibration, the unit needs to be scaled in Field Calibration. The Basic Calibration procedure is described below.

Note: To abort this calibration and reset to the previous settings, set the BASIC CAL switch(#3) OFF prior to the final setting of the OUTPUT CAL switch (Step 4.17) and turn off power for 5 seconds. Then turn on power and the previous settings will be loaded.

- 4.1 Connect a precision mV source with an accuracy of 0.02% to Terminal #7 (TC+ Input) and Terminal #8 (TC- Input). Set the ICE PT EN/DIS switch (#4), RANGE (#9&#10), TYPE (#6, #7, and #8), OUTPUT CAL (#1), and FIELD CAL (#2) switches OFF. Set the BASIC CAL switch (#3) ON.
- 4.2 Apply power and allow a 30 minute warm-up period. [Output goes to -0.9 mA, 3.4 mA, or -0.5 V nominal]
- 4.3 Set the OUTPUT CAL switch (#1) ON and then OFF.
- 4.4 Input -9 mV and wait 5 seconds.
- 4.5 Set the OUTPUT CAL switch (#1) ON and then OFF.
- 4.6 Input 6 mV and wait 5 seconds.
- 4.7 Set the OUTPUT CAL switch (#1) ON and then OFF.
- 4.8 Input 22 mV and wait 5 seconds.
- 4.9 Set the OUTPUT CAL switch (#1) ON and then OFF.
- 4.10 Input 41mV and wait 5 seconds.
- 4.11 Set the OUTPUT CAL switch (#1) ON and then OFF.
- 4.12 Input 63 mV and wait 5 seconds.
- 4.13 Set the OUTPUT CAL switch (#1) ON and then OFF.
- 4.14 Input 77 mV and wait 5 seconds.
- 4.15 Set the OUTPUT CAL switch (#1) ON and then OFF.
- 4.16 Ice Point Calibration.
  - a. If ice point calibration is not desired, go to step 4.17.
  - b. To Enable ice point calibration, set the FIELD CAL switch (#2) ON.
    1. Connect a precision thermometer (accuracy of 0.1°C) to the unused terminal beside the TC Input terminals.
    2. Allow 5 minutes for the temperature to equalize.
    3. Using the temperature indicated by the precision thermometer, input an equivalent 1 mV/°C signal to the TC Input terminals.
- 4.17 Set the OUTPUT CAL switch (#1) ON and then OFF.
- 4.18 Set the BASIC CAL switch (#3) and FIELD CAL switch (#2) OFF. [Output increases to -0.8 mA, 3.5 mA, or -0.4 V nominal, or more]
- 4.19 Perform a Field Calibration. (See Section 1.0)

## INSTALLATION

The unit is equipped with a universal mounting foot for attachment to standard DIN style mounting rails, including G profile rail according to EN50035 - G32 , and top hat (T) profile rail according to EN50022 - 35 x 7.5 and 35 x 15. The unit should be installed in a location that does not exceed the maximum operating temperature and provides good air circulation. Placing the unit near devices that generate excessive heat should be avoided.

### G Rail Installation

To install the ITMA on a "G" style DIN rail, angle the module so that the upper groove of the "foot" catches under the lip of the top rail. Push the module toward the rail until it snaps into place. To remove a module from the rail, push up on the bottom of the module while pulling out away from the rail.

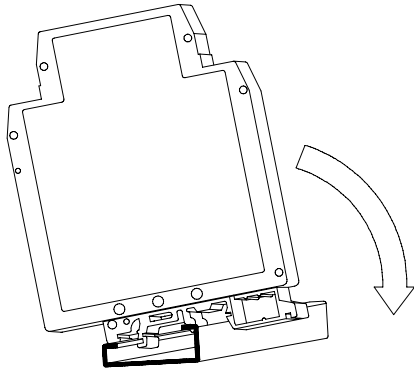

### T Rail Installation

To install the ITMA on a "T" style rail, angle the module so that the top groove of the "foot" is located over the lip of the top rail. Push the module toward the rail until it snaps into place. To remove a module from the rail, insert a screwdriver into the slot on the bottom of the "foot", and pry upwards on the module until it releases from the rail.

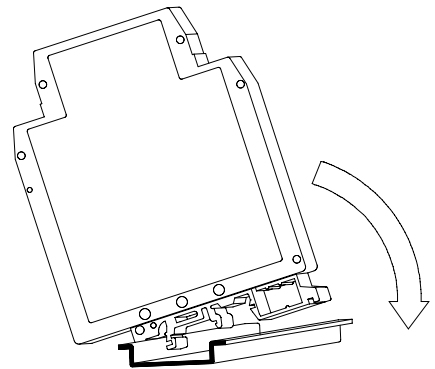

## APPLICATION

The temperature of certain industrial plastics is critical for melt flow of an injection molding process. Different plastic grades and the complexity of the mold determine required temperatures for efficient material flow. The master control room monitors the temperature of the melt flow of each injection mold machine. They will determine whether the operator may start the process on his machine or override the injection molding process. The injection molding machines are located throughout the plant, posing a thermocouple signal loss problem from long cable runs. The ITMA DC powered unit is mounted at the machine and uses the local 24 VDC for power. The signal loss problem is solved using the 4 to 20 mA analog output for the long cable run to the master control room.

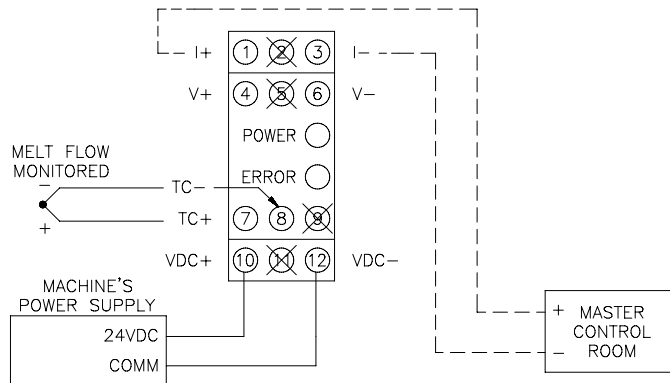

## ORDERING INFORMATION

MODEL NO.	DESCRIPTION	PART NUMBER
ITMA	Intelligent Thermocouple Module	ITMA3035

This page intentionally left blank

#### **LIMITED WARRANTY**

The Company warrants the products it manufactures against defects in materials and workmanship for a period limited to two years from the date of shipment, provided the products have been stored, handled, installed, and used under proper conditions. The Company's liability under this limited warranty shall extend only to the repair or replacement of a defective product, at The Company's option. The Company disclaims all liability for any affirmation, promise or representation with respect to the products.

The customer agrees to hold Red Lion Controls harmless from, defend, and indemnify RLC against damages, claims, and expenses arising out of subsequent sales of RLC products or products containing components manufactured by RLC and based upon personal injuries, deaths, property damage, lost profits, and other matters which Buyer, its employees, or sub-contractors are or may be to any extent liable, including without limitation penalties imposed by the Consumer Product Safety Act (P.L. 92-573) and liability imposed upon any person pursuant to the Magnuson-Moss Warranty Act (P.L. 93-637), as now in effect or as amended hereafter.

No warranties expressed or implied are created with respect to The Company's products except those expressly contained herein. The Customer acknowledges the disclaimers and limitations contained herein and relies on no other warranties or affirmations.

Red Lion Controls  
20 Willow Springs Circle  
York PA 17406  
Tel +1 (717) 767-6511  
Fax +1 (717) 764-0839

Red Lion Controls BV  
Basicweg 11b  
NL - 3821 BR Amersfoort  
Tel +31 (0) 334 723 225  
Fax +31 (0) 334 893 793

Red Lion Controls AP  
31, Kaki Bukit Road 3,  
#06-04/05 TechLink  
Singapore 417818  
Tel +65 6744-6613  
Fax +65 6743-3360