

Fiber Guide model SFA-FGD1HD available for routing fibers (refer to p/n 123560).

Refer to PICO-GUARD Controller Manual (p/n 69761) and PICO-GUARD Application and Design Guide (p/n 69763) for complete installation and operation information.

These fiber optic safety switches are intended to be used with PICO-GUARD series controllers in personnel safety and equipment-protection applications.

Features

- Compact, non-contact, easy-to-install means of interlocking doors, guards, gates, and covers
- Uses Banner 2.2 mm OD plastic fiber optic cable (1 mm core); choose PE or PTFE-coated fiber models
- Designed to meet Safety Category 4 applications with one switch pair per guard (per ISO13849-1)
- Impact- and chemically-resistant zinc and glass construction
- Environmental rating of IEC IP67
- Attenuator available (see p/n 109910) for reducing excess gain in short-run applications
- Splice available for easy connection of two fiber sections (see p/n 109910)

Models

Model		Fiber Length
PE Fiber	PTFE-Coated Fiber	
SFI-D1HDPS6	SFI-D1HDPXT6	1.8 m (6')
SFI-D1HDPS15	SFI-D1HDPXT15	4.5 m (15')
SFI-D1HDPS30	SFI-D1HDPXT30	9.0 m (30')
SFI-D1HDPS50	SFI-D1HDPXT50	15.3 m (50')
SFI-A1HD		-

Specifications

Operating Distance	1-50 mm (0.04" - 2") max.
Switching Distance	See Figure 1.
Mounting	Holes for M6 screws (mounting hardware not included)
Construction	Cast zinc housing, glass window, PTFE-sheathed or PE plastic fiber
Temperature Range	0° to +70° C (+32° to 158°F)
Max. Relative Humidity	95% (non-condensing)
Environmental Rating	IEC IP67

Dimensions

Model SFI-A1HD

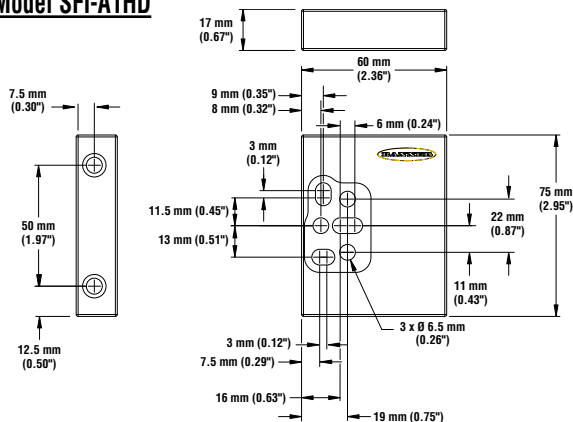

SFI-D1HDP.. Models

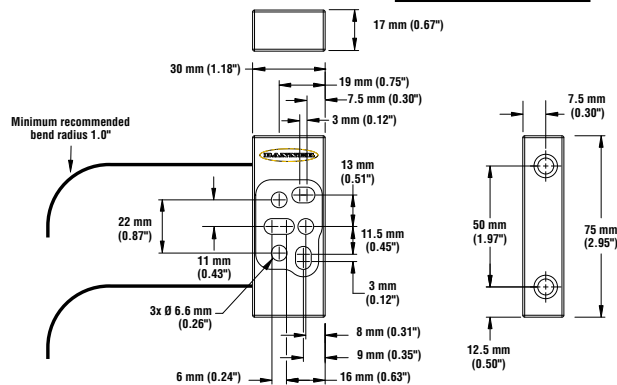

PICO-GUARD™ Fiber Optic Safety Interlock Switches – Zinc Housing

Models SFI-A1HD and SFI-D1HDP.

Mounting and Fiber Connection

The path of travel, or movement, of the Fiber Optic Safety Interlock Switch **must always be perpendicular** (at a right angle) to the optical axis to ensure proper switching. Perpendicular displacement along the optical centerline greater than the switching distance will result in a beam break and a stop condition.

Any opening in a guard must comply with the minimum safe opening requirements to prevent exposure to a hazard. See OSHA O-10 Table listed in 29CFR1910.217 or the relevant standard for further information.

With the guard closed, the maximum allowed distance from lens face to lens face is 50 mm (2"). Ensure that there is a minimum 1 mm (0.04") separation between switches and do not use the switches as an end-of-travel or mechanical stop.

Do not exceed the minimum bend radius of 25 mm (1") for the fiber optic cable. The excess gain is dependent on switch pair alignment, fiber length, fiber bend radius, and other loss factors, which may result in a weak signal or beam break condition (e.g., increased transitional area, see Figure 1). See Bannerengineering.com for an on-line gain estimator or the Application and Design Guide for more information.

Switching Specifications

The switching distance (D) is a "±" value; it is dependent on the distance between the optical switches (X) and their alignment along the optical axis. Perpendicular displacement greater than "D" will result in a stop condition. **(See Application and Design Guide for complete information.)**

The excess gain may fall below the threshold level before the switching distance dependent on alignment, fiber length, and other loss factors, which will result in a weak signal or beam break condition before distance D. This region is referred to as the **Transition Area**.

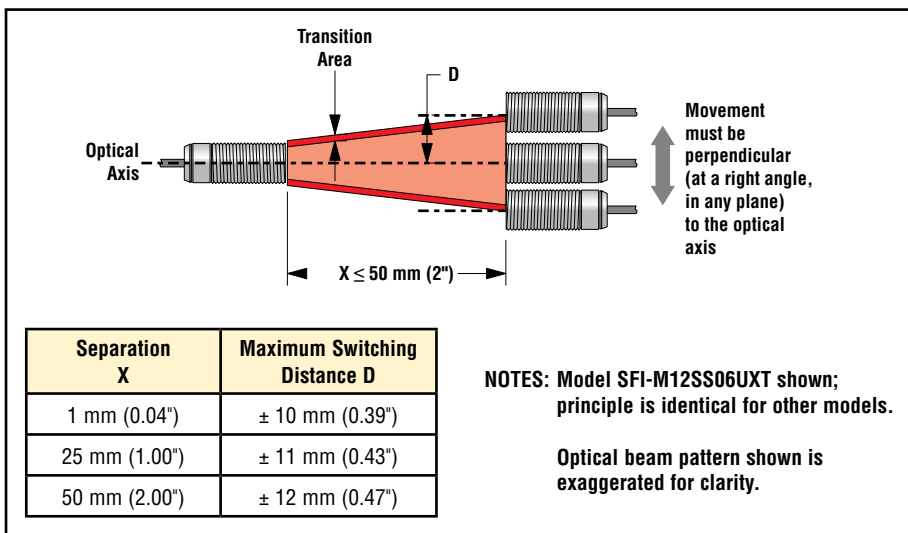

Figure 1. Switch alignment



Warning ... Avoid Misapplication of this Product

PICO-GUARD optical elements must be properly installed and interfaced with a PICO-GUARD Fiber Optic Controller to be considered a safeguard.

See the PICO-GUARD Controller Instruction Manual (p/n 69761) and the PICO-GUARD Application and Design Guide (p/n 69763) for complete installation instructions, maintenance instructions, and application limitations.

Use of a Banner PICO-GUARD Fiber Optic Safety Interlock Switch is generally not allowed for:

- Establishing a beam for presence-sensing safeguarding (e.g., perimeter guarding),
- Linear (parallel) movement along the optical axis (see Figure 2 and the Application and Design Guide), or
- Machinery with long stopping time and without a guard-locking mechanism.

Follow all installation and maintenance instructions with extreme care. **The user is responsible for following all local, state, and national laws, rules, codes, and regulations relating to the use of this safeguarding system in any particular application.**



Warning ... Explosive Environments

When used in a potentially explosive environment, and if there is a possibility of a significant static accumulation that could cause an electrical spark, **SFI series Fiber Optic Safety Interlock Switches must be mounted on an electrically grounded surface.**



WARRANTY: Banner Engineering Corp. warrants its products to be free from defects for one year. Banner Engineering Corp. will repair or replace, free of charge, any product of its manufacture found to be defective at the time it is returned to the factory during the warranty period. This warranty does not cover damage or liability for the improper application of Banner products. This warranty is in lieu of any other warranty either expressed or implied.