

Hinge Wing Safety Interlock Switches

SI-HG80 Series Safety Interlock Switches Encapsulated in a Load-Bearing Hinge



Features

- Safety switch is integrated and encapsulated into a load-bearing hinge, providing a high degree of protection from intentional defeat
- Identical in appearance to non-switching blank hinge (see page 7)
- Switch components concealed inside the hinge are protected from mechanical impact, providing superior performance to actuator-activated safety switches; rated IEC IP67
- Hinge operates to a full 180° range of motion; safety switching point (guard-closed position) is adjustable over the full 0–180° operating range
- Hinge can support an axial load of 750 N and more than 1,000 N in radial direction
- When properly interfaced or used with an appropriate controller, two SI-HG80D.. switches can achieve safety category 4, per ISO 13849 (EN 954-1)
- Robust zinc die-cast housing is corrosion resistant
- Typical applications include:
 - Hinged covers and guards to machines
 - Hinged doors and gates in safety fencing systems
 - Modular aluminum framing

Models

Model	QD Connection	Contact Configuration (Closed State)	Contact Configuration (Open State)	Switching Diagram
SI-HG80DQD	Inline QD Fitting			<p>Contacts: □ Open ■ Closed ▒ Transition</p>
SI-HG80DQDR	Right-Angle QD Fitting			

NOTE: Terminal #3 is non-safety



Hinge Switches – SI-HG80 Series



Important Information Regarding the Use of Safety Switches

In the United States, the functions that Banner safety switches are intended to perform are regulated by the Occupational Safety and Health Administration (OSHA). Whether or not any particular safety switch installation meets all applicable OSHA requirements depends upon factors that are beyond the control of Banner Engineering Corp. These factors include the details of how the safety switches are applied, installed, wired, operated, and maintained.

Banner Engineering Corp. has attempted to provide complete application, installation, operation, and maintenance instructions. This information is found in the instruction manual packaged with each safety switch. In addition, we suggest that any questions regarding the use or installation of safety switches be directed to the factory applications department at the telephone numbers or address shown below.

Banner Engineering Corp. recommends that safety switches be applied according to the guidelines set forth in international (ISO/IEC) standards listed below. Specifically, Banner Engineering Corp. recommends application of these safety switches in a configuration which meets safety category 4, per ISO 13849 (EN954-1).

In addition, the user of Banner safety switches has the responsibility to ensure that all local, state, and national laws, rules, codes, and regulations relating to the use of Banner safety switches in any particular application are satisfied. Extreme care is urged that all legal requirements have been met and that all installations and maintenance instructions are followed.

Application Assistance

Toll Free: 1-888-3-SENSOR (1-888-373-6767)
Email: sensors@bannerengineering.com
Address: 9714 Tenth Avenue North
Minneapolis, MN 55441

U.S. Regulations Applicable to Use of Banner Safety Switches

OSHA Code of Federal Regulations: Title 29, Parts 1900 to 1910

Available from: Superintendent of Documents
Government Printing Office
P.O. Box 371954
Pittsburgh, PA 15250-7954
Tel: 202-512-1800

U.S. Standards Applicable to Use of Banner Safety Switches

ANSI B11 "Standards for Construction, Care, and Use of Machine Tools"
Available from: Safety Director
AMT—The Association for Manufacturing Technology
7901 Westpark Drive
McLean, VA 22102
Tel: 703-893-2900

Applicable European and International Standards

ISO/TR 12100-1 "Safety of Machinery—Basic Concepts, General Principles for Design"
(EN 292-18-2)
ISO 13852 (EN 294) "Safety of Machinery—Safety Distances to Prevent Danger Zones Being Reached by the Upper Limbs"
ISO 13853 (EN 811) "Safety of Machinery—Safety Distances to Prevent Danger Zones Being Reached by the Lower Limbs"
ISO 13849 (EN 954-1) "Safety of Machinery—Safety Related Parts of Control Systems"
ISO 13855 (EN 999) "Safety of Machinery—The Positioning of Protective Equipment in Respect to Approach Speeds of Parts of the Human Body"
ISO 14119 (EN 1088) "Safety of Machinery—Interlocking Devices Associated with Guards—Principles for Design and Selection"
IEC/EN 60204-1 "Safety of Machinery—Electrical Equipment of Machines"
IEC/EN 60947-5-1 "Low Voltage Switchgear—Electromechanical Control Circuit Devices"

Available from: Global Engineering Documents
15 Inverness Way East
Englewood, CO 80112-5704
Phone: 1-800-854-7179
Fax: 303-397-2740



WARNING ...

It must not be possible for personnel to reach any hazard point through an opened guard (or any opening) before hazardous machine motion has completely stopped. Please reference OSHA CFR 1910.217 and ANSI B11 standards (see page 2) for information on determining safety distances and safe opening sizes for your guarding devices.



CAUTION . . . End Stops

Do not use the switch as an end stop.
The operating angle of the switch must be limited by outer end stops.



CAUTION . . . Remove Set Screw Head

Shear off the hexagonal head of the set screw after it is set, and before using the switch.
If not, the safe activation of the switch can not be ensured.



Figure 1. Hinge switch with set screw head in place

Mechanical Installation

All mounting hardware is supplied by the user. Fasteners must be of sufficient strength to guard against breakage. Use of permanent fasteners or locking hardware is recommended to prevent loosening or displacement of the actuator and the switch body. The mounting holes in the switch body and the actuator accept M6 screws (see dimension drawings, pages 6 and 7).

Ensure that excessive force is not exerted by the weight and swing of the guard, gate, or door. (See specifications on page 6.)

Position blank hinges (if used) and the hinge switch(es) on the guard or gate while it is in its fully closed and latched position. Verify that the axis of rotation is identical for all hinges used. (Typically, this can be accomplished by using a straight edge along the long flat edge to ensure the switch bodies are parallel.) After the mounting hardware is secure, check the rotation of the guard or gate for misalignment and binding.

NOTE: A safety switch must be installed in a manner that discourages tampering or defeat.

Setting the Switch Point

1. Ensure that the hinge switches (and blind hinges, if used) are properly mounted and that the guard or gate swings freely throughout its range of motion without binding. If binding is noticed, repeat the mechanical installation procedures above.

2. Place the guard in its closed and latched position.

NOTE: Once the switch point is set, it can not be changed. Before proceeding, double-check that the installation is correct and the resulting switching action is what is expected.

3. Tighten the hexagonal set screw head with a 13 mm open-ended wrench (rotate clockwise when switch is mounted vertically and the nut is on top). See Figure 1.

4. Continue tightening until the set screw head shears completely off the switch. When the screwhead shears off, the switch point is set.

Hinge Switches – SI-HG80 Series

Electrical Connection

As illustrated in Figure 2, a normally-closed safety contact (i.e., a safety contact that is closed when the actuator is engaged) **from each of two safety switches per interlock guard** must connect to a 2-channel safety module or safety interface in order to achieve a control reliable interface to the master stop control elements of a machine. Examples of appropriate safety modules include 2-channel emergency stop (E-stop) safety modules and gate monitor safety modules.

Two functions of the safety module or safety interface are:

1. to provide a means of monitoring the contacts of both safety switches for contact failure, and to prevent the machine from restarting if either switch fails; and
2. to provide a reset routine after closing the guard and returning the safety switch contacts to their closed position. This prevents the controlled machinery from restarting by simply closing the guard. This necessary reset function is required by ANSI B11 and NFPA 79 machine safety standards.

Use only the positively driven, normally closed safety contact (between pins 1 and 2) from each switch for connection to the safety module. A typical use is to communicate with a process controller. Refer to the installation instructions provided with the safety modules for more information regarding the interface of the safety module to the machine stop control elements.

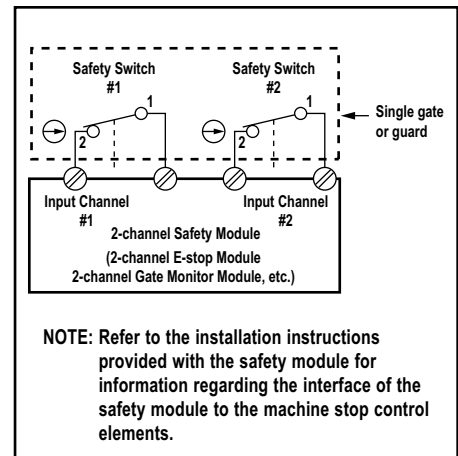

Figure 2. Connect two redundant safety switches per interlock guard to an appropriate 2-channel input safety module.



CAUTION . . .

Electrical Installation

Two safety switches must be used for each interlock guard to achieve control reliability or Safety Category 4 (per ISO 13849-1, EN 954-1) of a machine stop circuit. Use of only one safety switch per interlock guard is not recommended.

In addition, normally-closed safety contacts from each of the two safety switches should be connected to the two separate inputs of a 2-channel safety module or safety interface, as illustrated in Figure 6. This is required to provide monitoring for safety switch contact failure, and to provide the necessary reset routine, as required by IEC 60204-1 and NFPA 79 machine safety standards.



WARNING . . . Series Connection of Safety Interlock Switches

Monitoring multiple guards with a series connection of multiple safety interlock switches is not a Safety Category 4 Application (per ISO 13849-1, EN 954-1). A single failure may be masked or not detected at all. When such a configuration is used, procedures must be performed regularly to verify proper operation of each switch.

Periodic Checks

Safety switches should be checked at each shift change or machine setup by a *designated person* (see below) for:

1. Breakage of the switch body.
2. Confirmation that the safety switch is not being used as an end stop.
3. Verification that it is not possible to reach any hazard point through an opened guard (or any opening) before hazardous machine motion has completely stopped.
4. Verification that the hinge swings freely throughout its total operating range.
5. Loosening of mounting hardware.
6. Signs of deterioration or damage.
7. Signs of tampering or defeat to the switch or to the wiring interface to the machine.

A *designated person* is identified in writing by the employer as being appropriately trained to perform a specified checkout procedure.

Repairs

Do not attempt any repairs to the switch. It contains no field-replaceable components. Return the switch to the factory for warranty repair or replacement.

If it ever becomes necessary to return a switch to the factory, please do the following:

1. Contact the Banner applications engineering department at the number or address listed on the back cover. They will attempt to troubleshoot the system from your description of the problem. If they conclude that a component is defective, they will issue an RMA (Return Merchandise Authorization) number for your paperwork, and give you the proper shipping address.
2. Pack the switch carefully. Damage which occurs in shipping is not covered by warranty.

Hinge Switches – SI-HG80 Series

Specifications

Contact Rating	3A @ 250V ac max., 0.5 A @ 60V dc max. 2.5 kV max. transient tolerance NEMA A300 P300
European Rating	Utilization categories: AC15 and DC13 (IEC 90497-5-1) $U_i = 250V$ ac $I_{th} = 3A$
Minimum Switching Speed	20 operations per minute
Mechanical Life	1 million operations
Short Circuit Protection	6 amp Slow Blow, 10 amp Fast Blow. Recommended external fusing or overload protection.
Force Exerted by Guard per Switch	Axial: 750 N (165 lbf) max. Radial: 1000 N (220 lbf) max.
Operating Range	0° to 180°
Wire Connections	4-pin Micro-style quick-disconnect (QD) fitting. Cables are ordered separately; see page 7.
Construction	Zinc Die-cast (GD-Zn)
Environmental Rating	NEMA 4, IEC IP67
Operating Conditions	Temperature: -25° to +70° C (-13° to +158° F)
Weight	0.40 kg (0.88 lb)
Application Notes	To avoid excessive radial stress in applications containing large doors, the hinge switch should be mounted either in pairs of two, or in conjunction with a blank hinge (see page 7).
Certifications	

Dimensions

Model SI-HG80DQD

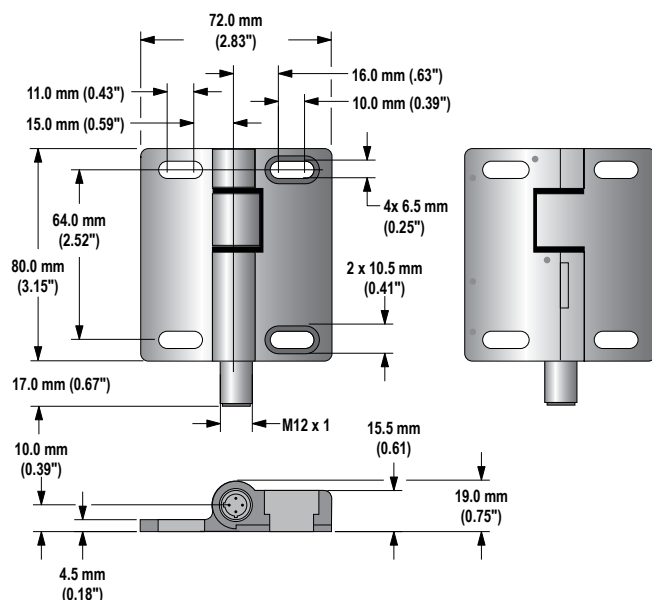

Model SI-HG80DQDR

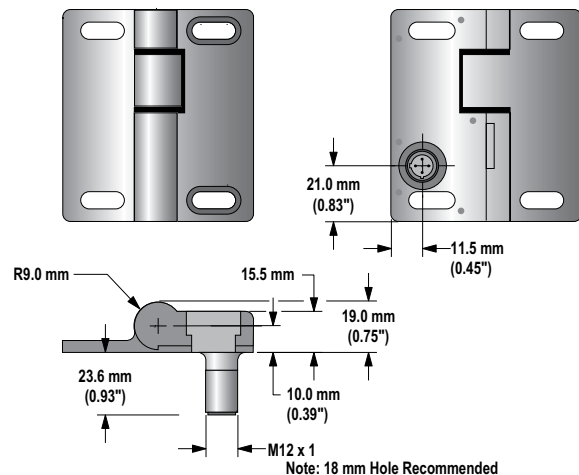

See page 7 for blank hinge dimensions.

Hinge Switches – SI-HG80 Series

Accessories

Quick-Disconnect Cables

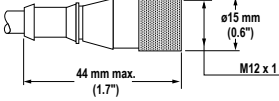
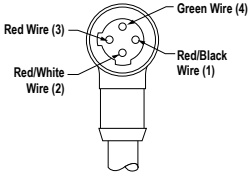
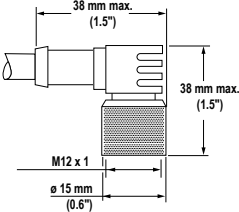
Style	Model	Length	Dimensions	Pinout
4-Pin Micro-style, Straight	MQEAC-406 MQEAC-415 MQEAC-430	2 m (6.5') 5 m (15') 9 m (30')		
4-Pin Micro-style, Right-angle	MQEAC-406RA MQEAC-415RA MQEAC-430RA	2 m (6.5') 5 m (15') 9 m (30')		

Blank Hinge

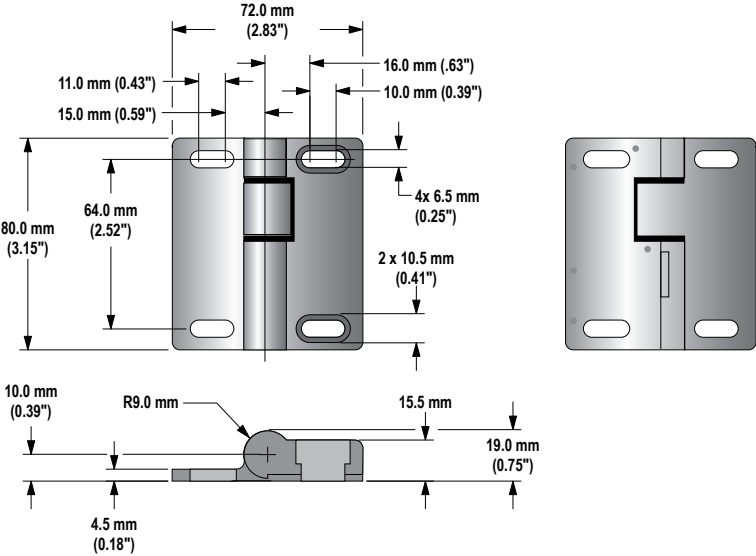
Model	Description	Dimensions
SI-HG80A	Same mechanical specifications as SI-HG80 Series Hinge Switches	

Hinge Switches – SI-HG80 Series



more sensors, more solutions

WARRANTY: Banner Engineering Corp. warrants its products to be free from defects for one year. Banner Engineering Corp. will repair or replace, free of charge, any product of its manufacture found to be defective at the time it is returned to the factory during the warranty period. This warranty does not cover damage or liability for the improper application of Banner products. This warranty is in lieu of any other warranty either expressed or implied.