





## Features

-  Positive-opening safety contacts (IEC 60947-5-1) (not dependent upon springs)
- Standard limit switch design
- In-line actuator; flexes in all directions
- Metal housing
- Spring-loaded actuator base
-  Protective Earth Terminal (IEC 60947-1) on models with metal housings

NOTE:  This symbol for a positive opening safety contact (IEC 60947-5-1) is used in the switching diagrams to identify the point in actuator travel where the normally closed safety contact is fully open.

## Models

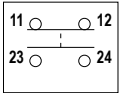
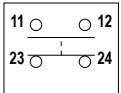
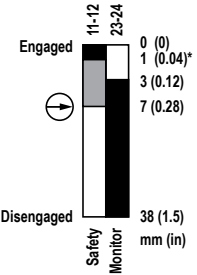
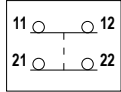
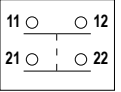
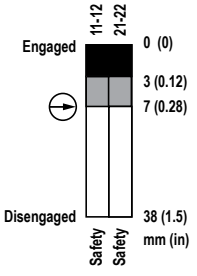
Kit Model†	Actuator Type†	Interlock Body†	Contact Configuration (Actuator Engaged)	Contact Configuration (Actuator Removed)	Switching Diagrams*
SI-LM40MKVD	SI-QM-90A Flexible, In-Line	SI-LM40KVD with Metal Housing			
SI-LM40MKVE		SI-LM40KVE with Metal Housing			

† A kit contains an interlock and actuator. Individual interlock bodies or actuators are for replacement purposes only. See Warning below.

Contacts:  Open  Closed  Transition

\* Please note that only 1 mm (0.04") of movement will open the closed contact.



### WARNING . . .

Spare actuators must NEVER be used to bypass or otherwise defeat the protective function of a safety switch. To do so may create an unsafe situation which could lead to serious injury or death.



# Machine Safety Switch – SI-LM40 Series Limit Switch Style



## Important Information Regarding the Use of Safety Switches

In the United States, the functions that Banner safety switches are intended to perform are regulated by the Occupational Safety and Health Administration (OSHA). Whether or not any particular safety switch installation meets all applicable OSHA requirements depends upon factors that are beyond the control of Banner Engineering Corp. These factors include the details of how the safety switches are applied, installed, wired, operated, and maintained.

Banner Engineering Corp. has attempted to provide complete application, installation, operation, and maintenance instructions. This information is found in the instruction manual packaged with each safety switch. In addition, we suggest that any questions regarding the use or installation of safety switches be directed to the factory applications department at the telephone numbers or address shown below.

Banner Engineering Corp. recommends that safety switches be applied according to the guidelines set forth in international (ISO/IEC) standards listed below. Specifically, Banner Engineering Corp. recommends application of these safety switches in a configuration which meets safety category 4, per ISO 13849 (EN954-1).

In addition, the user of Banner safety switches has the responsibility to ensure that all local, state, and national laws, rules, codes, and regulations relating to the use of Banner safety switches in any particular application are satisfied. Extreme care is urged that all legal requirements have been met and that all installations and maintenance instructions are followed.

### Application Assistance

**Toll Free:** 1-888-3-SENSOR (1-888-373-6767)  
**Email:** sensors@bannerengineering.com  
**Address:** 9714 Tenth Avenue North  
Minneapolis, MN 55441

### U.S. Regulations Applicable to Use of Banner Safety Switches

OSHA Code of Federal Regulations: Title 29, Parts 1900 to 1910

Available from: Superintendent of Documents  
Government Printing Office  
P.O. Box 371954  
Pittsburgh, PA 15250-7954  
Tel: 202-512-1800

### U.S. Standards Applicable to Use of Banner Safety Switches

ANSI B11 "Standards for Construction, Care, and Use of Machine Tools"  
Available from: Safety Director  
AMT—The Association for Manufacturing Technology  
7901 Westpark Drive  
McLean, VA 22102  
Tel: 703-893-2900

### Applicable European and International Standards

ISO/TR 12100-1 "Safety of Machinery—Basic Concepts, General Principles for Design"  
(EN292-18-2)  
ISO 13852 (EN 294) "Safety of Machinery—Safety Distances to Prevent Danger Zones Being Reached by the Upper Limbs"  
ISO 13853 (EN 811) "Safety of Machinery—Safety Distances to Prevent Danger Zones Being Reached by the Lower Limbs"  
ISO 13849 (EN 954-1) "Safety of Machinery—Safety Related Parts of Control Systems"  
ISO 13855 (EN 999) "Safety of Machinery—The Positioning of Protective Equipment in Respect to Approach Speeds of Parts of the Human Body"  
ISO 14119 (EN 1088) "Safety of Machinery—Interlocking Devices Associated with Guards—Principles for Design and Selection"  
IEC/EN 60204-1 "Safety of Machinery—Electrical Equipment of Machines"  
IEC/EN 60947-5-1 "Low Voltage Switchgear—Electromechanical Control Circuit Devices"

Available from: Global Engineering Documents  
15 Inverness Way East  
Englewood, CO 80112-5704  
Phone: 1-800-854-7179  
Fax: 303-397-2740

# Machine Safety Switch – SI-LM40 Series Limit Switch Style

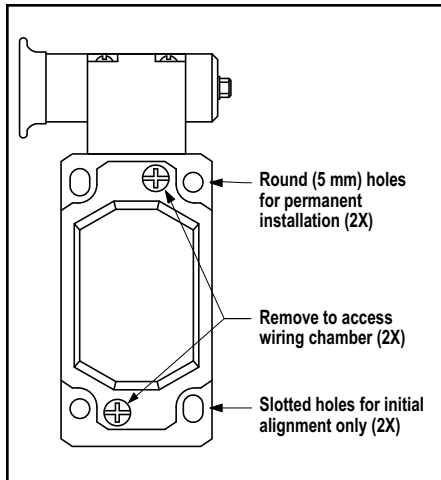



Figure 1. Features

 **WARNING ...**

It must not be possible for personnel to reach any hazard point through an opened guard (or any opening) before hazardous machine motion has completely stopped. Please reference OSHA CFR 1910.217 and ANSI B11 standards (see page 2) for information on determining safety distances and safe opening sizes for your guarding devices.

## Mechanical Installation

All mounting hardware is supplied by the user. The fasteners must be of sufficient strength to guard against incidental breakage. Use of permanent fasteners or locking hardware is recommended to prevent loosening or displacement of the actuator and switch body.

**NOTE:** The slotted holes in the switch body must **ONLY** be used for alignment during installation (see Figure 1). The round 5 mm holes (only) must be used for permanent mounting to prevent loosening or displacement of the actuator and the switch body. Only M5 (#10) screws (customer supplied), should be used.

There are four holes on a mounting pattern of 30 x 60 mm. The actuator has four M4 tapped mounting holes on a 26 mm (1.02") square pattern (see dimensions on page 7).

Position the switch, with its actuator fully engaged, in the mounting location and mark the mounting holes. Drill the required holes and fasten the switch body and the actuator in place. After the mounting hardware is secure, check the actuator/switch engagement for misalignment and binding.

The actuator is spring-loaded to allow positive pressure to be applied when the guard is closed. However, the switch must never serve as the mechanical end stop for a guard door or gate. Positive pressure for the actuator engagement is desirable, because only 1 mm (0.04") of actuator travel from the point of full engagement is required to open the safety contact.

### IMPORTANT:

1. A safety switch must be installed in a manner which discourages tampering or defeat. Mount each switch to prevent bypassing of the switching function at the terminal chamber.
2. A switch and its actuator must never be used as a mechanical stop.
3. Ensure proper placement of gasket when rotating head. Failure to do so will reduce the environmental rating.

# Machine Safety Switch – SI-LM40 Series Limit Switch Style

## Electrical Installation

### Access to the Wiring Chamber

The wiring chamber is accessed via a cover plate. The metal switch body uses two screws to hold the cover plate on. A conduit adapter is supplied to convert the M20 x 1.5 thread to ½"-14 NPT. An accessory cable gland which fits the M20 x 1.5 thread is available (see page 7).

### Connection to the Machine

Two contacts are offered. The contact between terminals 11 and 12 or 21 and 22 is the safety contact, which is closed (i.e., it conducts) when the actuator is engaged. The normally open contact located between terminals 23 and 24 is considered a monitoring contact, which should not be used for safety switching.

As illustrated in Figure 2, a normally closed safety contact (i.e., a safety contact that is closed when the actuator is engaged) from **each of two safety switches per interlock guard** must connect to a 2-channel safety module or safety interface in order to achieve a control reliable interface to the master stop control elements of a machine. Examples of appropriate safety modules include 2-channel emergency stop (E-stop) safety modules and gate monitor safety modules.

Two functions of the safety module or safety interface are:

1. to provide a means of monitoring the contacts of both safety switches for contact failure, and to prevent the machine from restarting if either switch fails; and
2. to provide a reset routine after closing the guard and returning the safety switch contacts to their closed position. This prevents the controlled machinery from restarting by simply reinserting the safety switch actuators. This necessary reset function is required by ANSI B11 and NFPA 79 machine safety standards.

Use only a positively driven, normally closed safety contact from each switch for connection to the safety module. *The normally open contact may be used for control functions that are not safety-related.* A typical use is to communicate with a process controller. Refer to the installation instructions provided with the safety modules for more information regarding the interface of the safety module to the machine stop control elements.



### CAUTION . . .

#### Electrical Installation

Two safety switches must be used for each interlock guard to achieve control reliability or Safety Category 4 (per ISO 13849-1, EN 954-1) of a machine stop circuit. Use of only one safety switch per interlock guard is not recommended.

In addition, normally-closed safety contacts from each of the two safety switches should be connected to the two separate inputs of a 2-channel safety module or safety interface, as illustrated in Figure 6. This is required to provide monitoring for safety switch contact failure, and to provide the necessary reset routine, as required by IEC 60204-1 and NFPA 79 machine safety standards.



### WARNING . . . Series Connection of Safety Interlock Switches

Monitoring multiple guards with a series connection of multiple safety interlock switches is not a Safety Category 4 Application (per ISO 13849-1, EN 954-1). A single failure may be masked or not detected at all. When such a configuration is used, procedures must be performed regularly to verify proper operation of each switch.

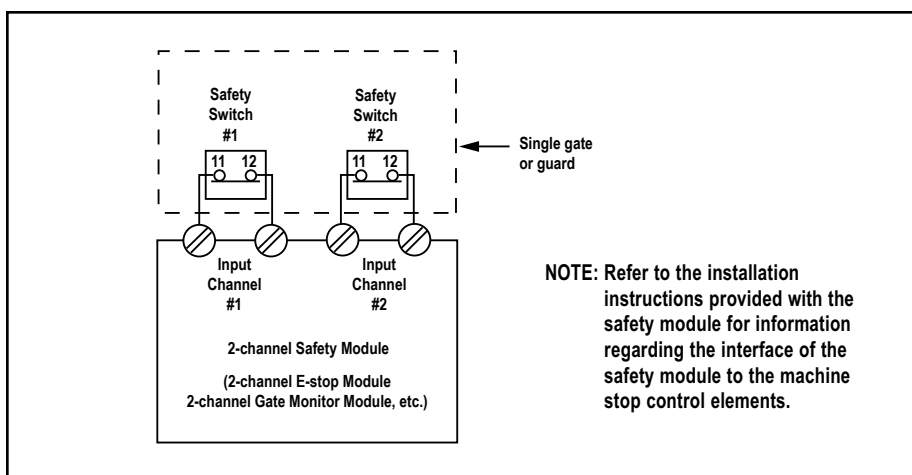

Figure 2. Connect two redundant safety switches per interlock guard to an appropriate 2-channel input safety module.

# Machine Safety Switch – SI-LM40 Series Limit Switch Style

## Periodic Checks

Safety switches should be checked at each shift change or machine setup by a *designated person* (see below) for:

1. Breakage of the switch body or actuator,
2. Good alignment and full engagement of the actuator with the receptor,
3. Confirmation that the safety switch is not being used as an end stop,
4. Loosening of the switch or actuator mounting hardware, and
5. Verification that it is not possible to reach any hazard point through an opened guard (or any opening) before hazardous machine motion has completely stopped.

In addition, a *qualified person* should check for the following on a periodic schedule, determined by the user, based upon the severity of the operating environment and the frequency of switch actuations:

1. Check the wiring chamber for signs of contamination.
2. Check the contacts for signs of deterioration or damage.
3. Inspect the electrical wiring for continuity and damage.
4. Verify that wiring conforms to the instructions on page 4 of this data sheet.

A *designated person* is identified in writing by the employer as being appropriately trained to perform a specified checkout procedure. A *qualified person* possesses a recognized degree or certificate or has extensive knowledge, training, and experience to be able to solve problems relating to the safety switch installation (ANSI B30.2).

## Repairs



**Do not attempt any repairs to the switch. It contains no field-replaceable components. Return the switch to the factory for warranty repair or replacement.**

If it ever becomes necessary to return a switch to the factory, please do the following:

1. Contact the Banner applications engineering department at the number or address listed on the back cover. They will attempt to troubleshoot the system from your description of the problem. If they conclude that a component is defective, they will issue an RMA (Return Merchandise Authorization) number for your paperwork, and give you the proper shipping address.
2. Pack the switch carefully. Damage which occurs in shipping is not covered by warranty.

# Machine Safety Switch – SI-LM40 Series Limit Switch Style

## Specifications

<b>Contact Rating</b>	10A @ 24V ac, 10A @ 110V ac, 6A @ 230V ac 6A @ 24V dc 2.5 kV max. transient tolerance NEMA A300 P300																	
<b>European Rating</b>	<b>Utilization categories:</b> AC15 and DC13 (IEC 60947-5-1)  U <sub>i</sub> = 500V ac I <sub>th</sub> = 10A	<table border="1"> <thead> <tr> <th colspan="3">40-60 Hz</th> </tr> <tr> <th>U<sub>e</sub> V</th> <th>I<sub>e</sub>/AC-15 A</th> <th>I<sub>e</sub>/DC-13 A</th> </tr> </thead> <tbody> <tr> <td>24</td> <td>10</td> <td>6</td> </tr> <tr> <td>110</td> <td>10</td> <td>1</td> </tr> <tr> <td>230</td> <td>6</td> <td>0.4</td> </tr> </tbody> </table>		40-60 Hz			U <sub>e</sub> V	I <sub>e</sub> /AC-15 A	I <sub>e</sub> /DC-13 A	24	10	6	110	10	1	230	6	0.4
40-60 Hz																		
U <sub>e</sub> V	I <sub>e</sub> /AC-15 A	I <sub>e</sub> /DC-13 A																
24	10	6																
110	10	1																
230	6	0.4																
<b>Contact Material</b>	Silver-nickel alloy																	
<b>Maximum Switching Speed</b>	10 operations per minute																	
<b>Maximum Actuator Speed</b>	0.5 m/second (20"/second)																	
<b>Minimum Actuator Engagement Radius</b>	150 mm (6")																	
<b>Actuator Extraction Force</b>	20 N (4.4 lbf)																	
<b>Short Circuit Protection</b>	6 amp Slow Blow, 10 amp Fast Blow. Recommended external fusing or overload protection.																	
<b>Mechanical Life</b>	25,000 operations																	
<b>Wire Connections</b>	Screw terminals with pressure plates accept the following wire sizes – <b>Stranded and solid:</b> 20 AWG (0.5 mm <sup>2</sup> ) to 16 AWG (1.5 mm <sup>2</sup> ) for one wire <b>Stranded:</b> 20 AWG (0.5 mm <sup>2</sup> ) to 18 AWG (1.0 mm <sup>2</sup> ) for two wires																	
<b>Cable Entry</b>	M20 x 1.5 threaded entrance. Adapter supplied to convert M20 x 1.5 to 1/2" – 14 NPT threaded entrance																	
<b>Construction</b>	Aluminum alloy die-cast housing																	
<b>Environmental Rating</b>	IEC IP65																	
<b>Operating Conditions</b>	<b>Temperature:</b> -30° to +80° C (-22° to +176° F)																	
<b>Weight</b>	0.31 kg (0.68 lb)																	
<b>Certifications</b>	  																	

# Machine Safety Switch – SI-LM40 Series Limit Switch Style

## Dimensions

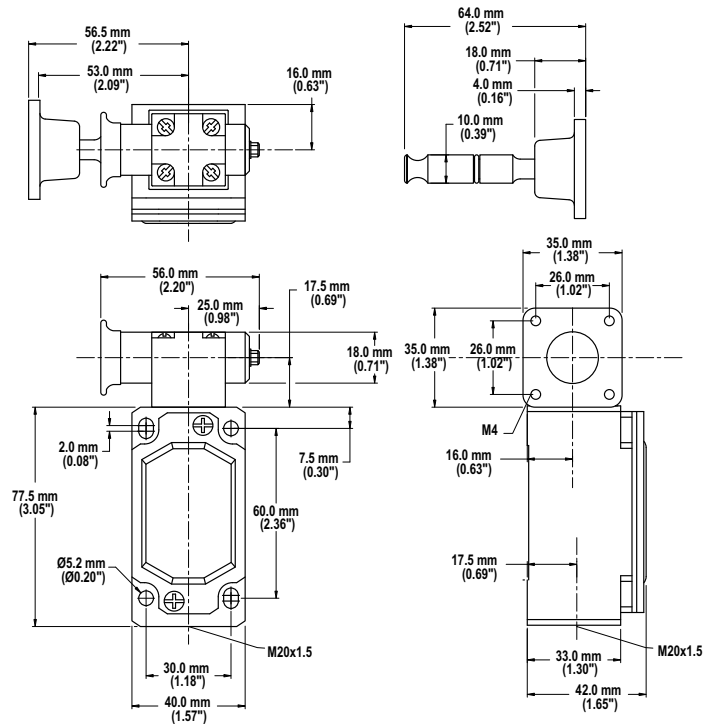

## Accessories

### Cable Glands

Size	Model	Used with Switch Models	For Cable Diameters	Dimensions
M20 x 1.5 Metal	SI-QM-CGM20	All	5.0 to 12.0 mm (0.20" to 0.47")	

### Replacement Parts

Description	Model*	Used with Switch Models	Thread Conversion	Dimensions
½"-14 NPT Metal Conduit Adaptor	SI-QM-M20	All	M20 x 1.5 to ½"-14 NPT	

\*NOTE: One conduit adaptor is supplied with each switch.

# Machine Safety Switch – SI-LM40 Series Limit Switch Style

---



**the machine safety specialist**

**WARRANTY:** Banner Engineering Corp. warrants its products to be free from defects for one year. Banner Engineering Corp. will repair or replace, free of charge, any product of its manufacture found to be defective at the time it is returned to the factory during the warranty period. This warranty does not cover damage or liability for the improper application of Banner products. This warranty is in lieu of any other warranty either expressed or implied.