



### POWER SUPPLY

- AC 100-240V Wide-range Input
- Width only 82mm
- Efficiency up to 94.0%
- 150% (720W) Peak Load Capability
- Safe Hiccup<sup>PLUS</sup> Overload Mode
- Easy Fuse Tripping due to High Overload Current
- Active Power Factor Correction (PFC)
- Negligible low Inrush Current Surge
- Short-term Operation down to 60Vac and up to 300Vac
- Full Power Between -25°C and +60°C
- DC-OK Relay Contact
- Quick-connect Spring-clamp Terminals
- 3 Year Warranty

### GENERAL DESCRIPTION

The most outstanding features of this Dimension Q-Series DIN-rail power supply are the high efficiency and the small size, which are achieved by a synchronous rectification and further novel design details.

With short-term peak power capability of 150% and built-in large sized output capacitors, these features help start motors, charge capacitors and absorb reverse energy and often allow a unit of a lower wattage class to be used.

High immunity to transients and power surges as well as low electromagnetic emission makes usage in nearly every environment possible.

The integrated output power manager, a wide range input voltage design and virtually no input inrush current make installation and usage simple. Diagnostics are easy due to the dry DC-ok contact, a green DC-ok LED and red overload LED.

Unique quick-connect spring-clamp terminals allow a safe and fast installation and a large international approval package for a variety of applications makes this unit suitable for nearly every situation.

### ORDER NUMBERS

|              |                 |                      |
|--------------|-----------------|----------------------|
| Power Supply | <b>QS20.361</b> | 36-42V Standard unit |
| Accessory    | ZM2.WALL        | Wall mount bracket   |
|              | ZM15.SIDE       | Side mount bracket   |
|              | YR40.482        | Redundancy module    |

### SHORT-FORM DATA

|                   |                  |                 |
|-------------------|------------------|-----------------|
| Output voltage    | DC 36V           |                 |
| Adjustment range  | 36 - 42V         |                 |
| Output current    | 13.3 – 11.4A     | continuous      |
|                   | 20 – 17.1A       | for typ. 4s     |
| Output power      | 480W             | continuous      |
|                   | 720W             | for typ. 4s     |
| Output ripple     | < 100mVpp        | 20Hz to 20MHz   |
| Input voltage     | AC 100-240V      | ±15%            |
| Mains frequency   | 50-60Hz          | ±6%             |
| AC Input current  | 4.56 / 2.48A     | at 120 / 230Vac |
| Power factor      | 0.95 / 0.90      | at 120 / 230Vac |
| AC Inrush current | typ. 9 / 7A peak | at 120 / 230Vac |
| Efficiency        | 92.5 / 94.0%     | at 120 / 230Vac |
| Losses            | 38.9 / 30.6W     | at 120 / 230Vac |
| Temperature range | -25°C to +70°C   | operational     |
| Derating          | 12W/°C           | +60 to +70°C    |
| Hold-up time      | typ. 32 / 51ms   | at 120 / 230Vac |
| Dimensions        | 82x124x127mm     | WxHxD           |

### MARKINGS



### INDEX

|   | Page |   | Page |
|---|------|---|------|
| 1. Intended Use .....                   | 3    | 21. Accessories .....                           | 18   |
| 2. Installation Requirements.....       | 3    | 21.1. ZM2.WALL Wall Mounting Bracket.....       | 18   |
| 3. AC-Input.....                        | 4    | 21.2. ZM15.SIDE Side Mounting Bracket.....      | 18   |
| 4. DC-Input.....                        | 5    | 21.3. YR40.482 Redundancy Modules.....          | 19   |
| 5. Input Inrush Current .....           | 5    | 22. Application Notes .....                     | 20   |
| 6. Output .....                         | 6    | 22.1. Repetitive Pulse Loading.....             | 20   |
| 7. Hold-up Time.....                    | 8    | 22.2. Peak Current Capability .....             | 21   |
| 8. DC-OK Relay Contact .....            | 8    | 22.3. Back-feeding Loads .....                  | 21   |
| 9. Efficiency and Power Losses.....     | 9    | 22.4. External Input Protection.....            | 21   |
| 10. Lifetime Expectancy and MTBF.....   | 10   | 22.5. Charging of Batteries .....               | 22   |
| 11. Functional Diagram.....             | 10   | 22.6. Output Circuit Breakers.....              | 22   |
| 12. Terminals and Wiring.....           | 11   | 22.7. Parallel Use to Increase Output Power.... | 23   |
| 13. Front Side and User Elements.....   | 12   | 22.8. Parallel Use for Redundancy .....         | 23   |
| 14. EMC.....                            | 13   | 22.9. Series Operation .....                    | 24   |
| 15. Environment.....                    | 14   | 22.10. Inductive and Capacitive Loads.....      | 24   |
| 16. Protection Features .....           | 15   | 22.11. Operation on Two Phases .....            | 24   |
| 17. Safety Features .....               | 15   | 22.12. Use in a Tightly Sealed Enclosure .....  | 24   |
| 18. Dielectric Strength .....           | 16   | 22.13. Mounting Orientations .....              | 25   |
| 19. Approvals.....                      | 16   |   |      |
| 20. Physical Dimensions and Weight..... | 17   |   |      |

The information presented in this document is believed to be accurate and reliable and may change without notice. No part of this document may be reproduced or utilized in any form without permission in writing from the publisher.

### TERMINOLOGY AND ABBREVIATIONS

|  |   |
|--|---|
| <b>PE and <math>\oplus</math> symbol</b> | PE is the abbreviation for <b>Protective Earth</b> and has the same meaning as the symbol $\oplus$ .  |
| <b>Earth, Ground</b>                     | This document uses the term "earth" which is the same as the U.S. term "ground".  |
| <b>T.b.d.</b>                            | To be defined, value or description will follow later.  |
| <b>AC 230V</b>                           | A figure displayed with the AC or DC before the value represents a nominal voltage with standard tolerances (usually $\pm 15\%$ ) included.<br>E.g.: DC 12V describes a 12V battery disregarding whether it is full (13.7V) or flat (10V) |
| <b>230Vac</b>                            | A figure with the unit (Vac) at the end is a momentary figure without any additional tolerances included.   |
| <b>50Hz vs. 60Hz</b>                     | As long as not otherwise stated, AC 230V parameters are valid at 50Hz mains frequency.  |
| <b>may</b>                               | A key word indicating flexibility of choice with no implied preference.   |
| <b>shall</b>                             | A key word indicating a mandatory requirement.  |
| <b>should</b>                            | A key word indicating flexibility of choice with a strongly preferred implementation.   |

### 1. INTENDED USE

This device is designed for installation in an enclosure and is intended for the general use such as in industrial control, office, communication, and instrumentation equipment.

Do not use this power supply in equipment, where malfunction may cause severe personal injury or threaten human life.

This device is designed for use in hazardous, non-hazardous, ordinary or unclassified locations.

### 2. INSTALLATION REQUIREMENTS

This device may only be installed and put into operation by qualified personnel.

This device does not contain serviceable parts. The tripping of an internal fuse is caused by an internal defect.

If damage or malfunction should occur during installation or operation, immediately turn power off and send unit to the factory for inspection.

Mount the unit on a DIN-rail so that the output terminals are located on the top and the input terminals are located on the bottom of the unit. For other mounting orientations see de-rating requirements in this document. See chapter 22.13.

This device is designed for convection cooling and does not require an external fan. Do not obstruct airflow and do not cover ventilation grid (e.g. cable conduits) by more than 30%!

Keep the following installation clearances: 40mm on top, 20mm on the bottom, 5mm on the left and right sides are recommended when the device is loaded permanently with more than 50% of the rated power. Increase this clearance to 15mm in case the adjacent device is a heat source (e.g. another power supply).

A disconnecting means shall be provided for the output of the power supplies when used in applications according to CSA C22.2 No 107.1-01.

**⚠ WARNING** Risk of electrical shock, fire, personal injury or death.

- Do not use the power supply without proper grounding (Protective Earth). Use the terminal on the input block for earth connection and not one of the screws on the housing.
- Turn power off before working on the device. Protect against inadvertent re-powering.
- Make sure that the wiring is correct by following all local and national codes.
- Do not modify or repair the unit.
- Do not open the unit as high voltages are present inside.
- Use caution to prevent any foreign objects from entering the housing.
- Do not use in wet locations or in areas where moisture or condensation can be expected.
- Do not touch during power-on, and immediately after power-off. Hot surfaces may cause burns.

#### Notes for use in hazardous location areas:

The power supply is suitable for use in Class I Division 2 Groups A, B, C, D locations.

#### WARNING EXPLOSION HAZARDS!

Substitution of components may impair suitability for this environment. Do not disconnect the unit or operate the voltage adjustment unless power has been switched off or the area is known to be non-hazardous.

A suitable enclosure must be provided for the end product which has a minimum protection of IP54 and fulfils the requirements of the EN 60079-15.

### 3. AC-INPUT

|                                 |      |             |   |
|---------------------------------|------|-------------|---|
| AC input                        | nom. | AC 100-240V | suitable for TN-, TT- and IT mains networks         |
| AC input range                  | min. | 85-276Vac   | continuous operation                                |
|                                 | min. | 60-85Vac    | full power for 200ms, no damage between 0 and 85Vac |
|                                 | min. | 276-300Vac  | < 500ms   |
| Allowed voltage L or N to earth | max. | 276Vac      | continuous, IEC 62103                               |
| Input frequency                 | nom. | 50-60Hz     | ±6%   |
| Turn-on voltage                 | typ. | 77Vac       | steady-state value, see Fig. 3-1                    |
| Shut-down voltage               | typ. | 73Vac       | steady-state value, see Fig. 3-1                    |
|                                 | typ. | 53Vac       | dynamic value                                       |

|                   |      | AC 100V | AC 120V | AC 230V |                                |
|-------------------|------|---------|---------|---------|--------------------------------|
| Input current     | typ. | 5.47A   | 4.56A   | 2.48A   | at 36V, 13.3A, see Fig. 3-3    |
| Power factor *)   | typ. | 0.96    | 0.95    | 0.90    | at 36V, 13.3A, see Fig. 3-4    |
| Crest factor **)  | typ. | 1.6     | 1.7     | 2.05    | at 36V, 13.3A                  |
| Start-up delay    | typ. | 640ms   | 610ms   | 660ms   | see Fig. 3-2                   |
| Rise time         | typ. | 80ms    | 80ms    | 80ms    | 0mF, 36V, 13.3A, see Fig. 3-2  |
|                   | typ. | 85ms    | 85ms    | 85ms    | 13mF, 36V, 13.3A, see Fig. 3-2 |
| Turn-on overshoot | max. | 100mV   | 100mV   | 100mV   | see Fig. 3-2                   |

\*) The power factor is the ratio of the true (or real) power to the apparent power in an AC circuit.

\*\*\*) The crest factor is the mathematical ratio of the peak value to RMS value of the input current waveform.

Fig. 3-1 Input voltage range

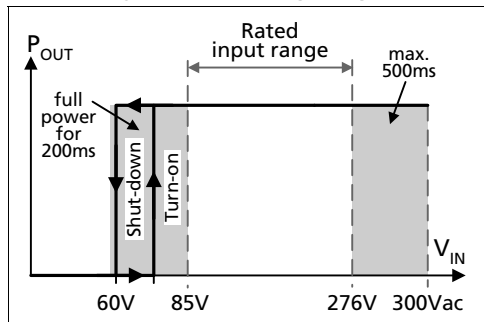

Fig. 3-2 Turn-on behavior, definitions

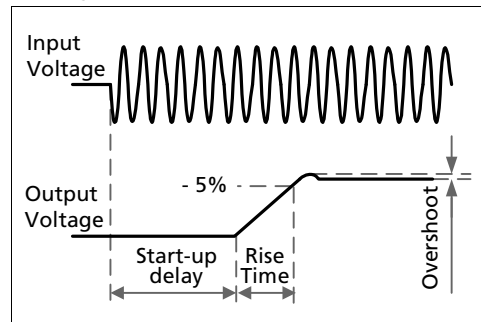

Fig. 3-3 Input current vs. output load at 36V

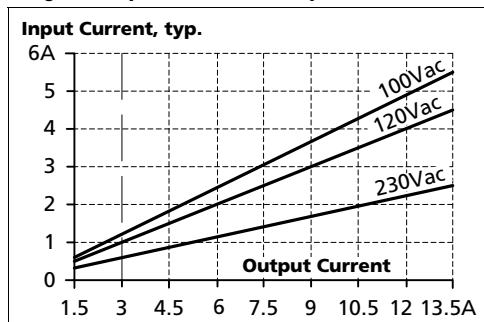
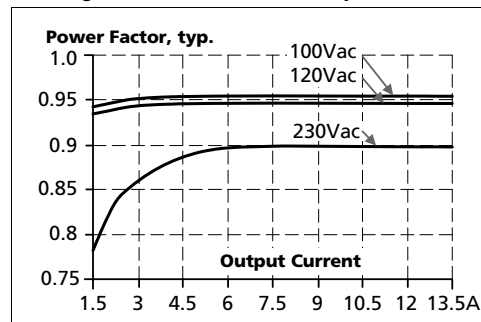

Fig. 3-4 Power factor vs. output load



### 4. DC-INPUT

|                              |      |             |                       |
|------------------------------|------|-------------|-----------------------|
| DC input                     | nom. | DC 110-150V | -20%/+25%             |
| DC input range               | min. | 88-187Vdc   |                       |
| DC input current             | typ. | 4.6A        | 110Vdc, at 36V, 13.3A |
| Allowed Voltage L/N to Earth | max. | 375Vdc      | IEC 62103             |
| Turn-on voltage              | typ. | 74Vdc       | steady state value    |
| Shut-down voltage            | typ. | 69Vdc       | steady state value    |

Fig. 4-1 Wiring for DC Input

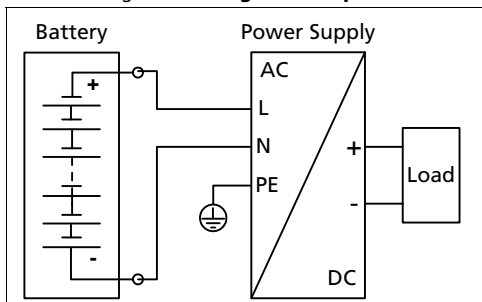

#### Instructions for DC use:

- Use a battery or similar DC source. For other sources contact PULS
- Connect +pole to L and -pole to N.
- Connect the PE terminal to an earth wire or to the machine ground.

### 5. INPUT INRUSH CURRENT

An active inrush limitation circuit limits the input inrush current after turn-on of the input voltage and after short input voltage interruptions.

The charging current into EMI suppression capacitors is disregarded in the first microseconds after switch-on.

|                  |      | AC 100V             | AC 120V             | AC 230V             |  |
|------------------|------|---------------------|---------------------|---------------------|--|
| Inrush current   | max. | 13A <sub>peak</sub> | 13A <sub>peak</sub> | 13A <sub>peak</sub> | over entire temperature range; mains interruptions > 750ms |
|                  | typ. | 5A <sub>peak</sub>  | 4A <sub>peak</sub>  | 7A <sub>peak</sub>  | over entire temperature range; mains interruptions > 750ms |
| Inrush energy    | max. | 5A <sup>2</sup> s   | 5A <sup>2</sup> s   | 5A <sup>2</sup> s   | over entire temperature range; mains interruptions > 750ms |
| Inrush delay (A) | typ. | 400ms               | 400ms               | 650ms               | see (A) in Fig. 5-1  |

Fig. 5-1 Input inrush current, typical behavior

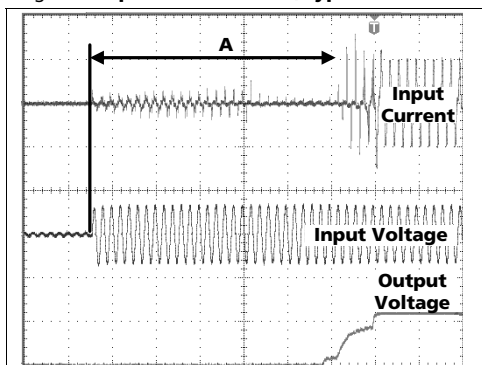

A.... Inrush delay

Input: 230Vac  
 Output: 36V, 13.3A  
 Ambient: 25°C  
 Upper curve: Input current 5A / DIV  
 Middle curve: Input voltage 500V / DIV  
 Lower curve: Output voltage 30V / DIV  
 Time basis: 100ms / DIV

### 6. OUTPUT

|                           |      |                                |   |
|---------------------------|------|--------------------------------|---|
| Output voltage            | nom. | 36V                            |   |
| Adjustment range          | min. | 36-42V                         | guaranteed  |
|                           | max. | 45V ****)                      | at clockwise end position of potentiometer                                  |
| Factory setting           | typ. | 36.0V                          | ±0.2%, at full load, cold unit  |
| Line regulation           | max. | 10mV                           | 60-300Vac   |
| Load regulation           | max. | 100mV                          | static value, 0A → 13.3A  |
| Ripple and noise voltage  | max. | 100mVpp                        | 20Hz to 20MHz, 50Ohm  |
| Output current            | nom. | 13.3A                          | continuously available at 36V, see Fig. 6-1                                 |
|                           | nom. | 11.4A                          | continuously available at 42V, see Fig. 6-1                                 |
|                           | nom. | 20A *)                         | short term available BonusPower® *)<br>at 36V, for typical 4s, see Fig. 6-1 |
|                           | nom. | 17.1A *)                       | short term available BonusPower® *)<br>at 42V, for typical 4s, see Fig. 6-1 |
| Output power              | nom. | 480W                           | continuously available  |
|                           | nom. | 720W *)                        | short term available BonusPower® *)   |
| BonusPower® time          | typ. | 4s                             | duration until the output voltage dips, see Fig. 6-2                        |
|                           | min. | 3.5s                           |   |
|                           | max. | 4.5s                           |   |
| BonusPower® recovery time | typ. | 7s                             | overload free time to reset power manager Fig. 6-4                          |
| Overload behaviour        |      | cont. current                  | output voltage > 30Vdc, see Fig. 6-1  |
|                           |      | Hiccup <sup>PLUS</sup> mode**) | output voltage < 30Vdc, see Fig. 6-1  |
| Short-circuit current     | min. | 20A ***)                       | load impedance 75mOhm, see Fig. 6-3   |
|                           | max. | 27A ***)                       | load impedance 75mOhm, see Fig. 6-3   |
|                           | max. | 9A ****)                       | average (R.M.S.) current, load impedance 75mOhm, see Fig. 6-3               |
| Output capacitance        | typ. | 8 500µF                        | included inside the power supply  |

\*) **BonusPower®, short term power capability (up to typ. 4s)**

The power supply is designed to support loads with a higher short-term power requirement without damage or shutdown. The short-term duration is hardware controlled by an output power manager. This BonusPower® is repeatedly available. Detailed information can be found in chapter 22.1. If the power supply is loaded longer with the BonusPower® than shown in the Bonus-time diagram (see Fig. 6-2), the max. output power is automatically reduced to 480W. If the power requirement is continuously above 480W and the voltage falls below approx. 30V (due to the current regulating mode at overload), the unit shuts-off and makes periodical restart attempts. This behaviour is called hiccup mode, which is described below. If the voltage is above 30V, the unit continuously delivers current.

\*\*\*) **Hiccup<sup>PLUS</sup> Mode**

At heavy overloads (when output voltage falls below 30V), the power supply delivers continuous output current for 2s. After this, the output is switched off for approx. 17s before a new start attempt is automatically performed. This cycle is repeated as long as the overload exists. If the overload has been cleared, the device will operate normally. See also Fig. 6-3. During the off-period a small rest voltage and rest current is present on the output.

\*\*\*\*) Discharge current of output capacitors is not included.

\*\*\*\*\*) This is the maximum output voltage which can occur at the clockwise end position of the potentiometer due to tolerances. It is not guaranteed value which can be achieved. The typical value is about 43.5V.

### Peak current capability (up to several milliseconds)

The power supply can deliver a peak current which is higher than the specified short term current. This helps to start current demanding loads or to safely operate subsequent circuit breakers.

The extra current is supplied by the output capacitors inside the power supply. During this event, the capacitors will be discharged and causes a voltage dip on the output. Detailed curves can be found in chapter 22.2.

|                           |      |                 |                                 |
|---------------------------|------|-----------------|---------------------------------|
| Peak current voltage dips | typ. | from 36V to 29V | at 27A for 50ms, resistive load |
|                           | typ. | from 36V to 27V | at 67A for 2ms, resistive load  |
|                           | typ. | from 36V to 25V | at 67A for 5ms, resistive load  |

Fig. 6-1 **Output voltage vs. output current, typ.**

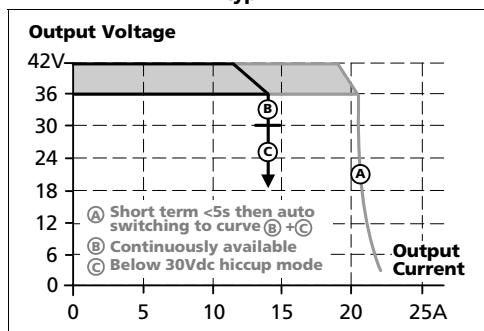

Fig. 6-2 **Bonus time vs. output power**

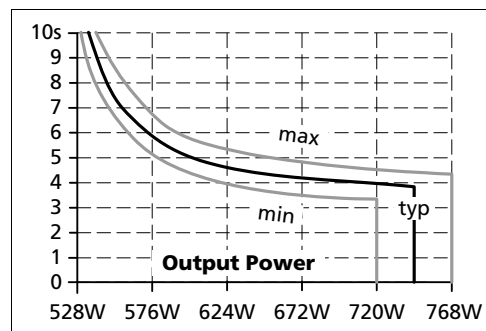

Fig. 6-3 **Short-circuit on output, hiccup mode (typ.)**

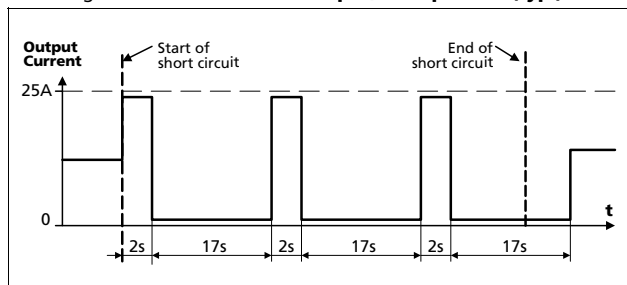
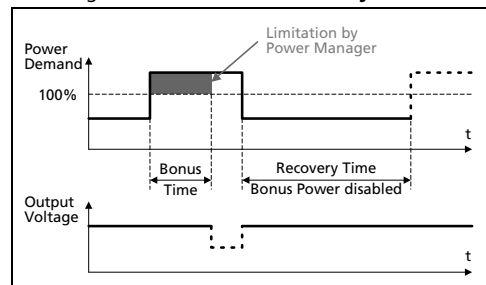

Fig. 6-4 **BonusPower® recovery time**



The BonusPower® is available as soon as power comes on and immediately after the end of an output short circuit or output overload.

Fig. 6-5 **BonusPower® after input turn-on**

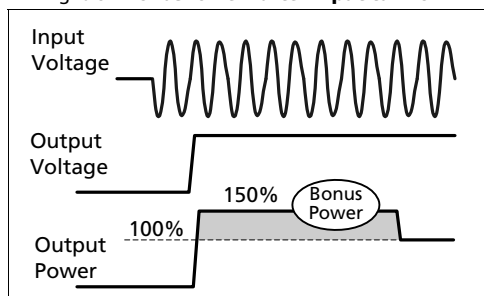
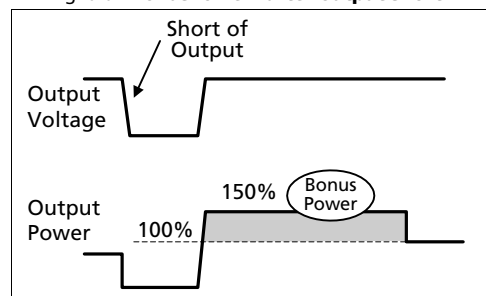

Fig. 6-6 **BonusPower® after output short**



### 7. HOLD-UP TIME

|              |      | AC 100V | AC 120V | AC 230V |                             |
|--------------|------|---------|---------|---------|-----------------------------|
| Hold-up Time | typ. | 64ms    | 64ms    | 99ms    | at 36V, 6.7A, see Fig. 7-1  |
|              | typ. | 32ms    | 32ms    | 51ms    | at 36V, 13.3A, see Fig. 7-1 |

Fig. 7-1 Hold-up time vs. input voltage

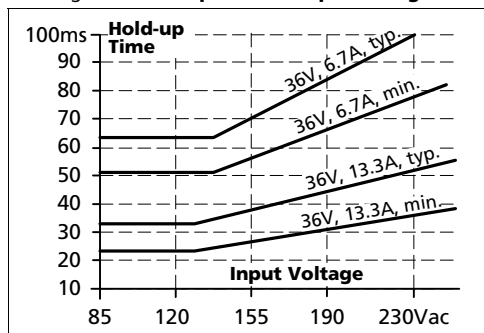
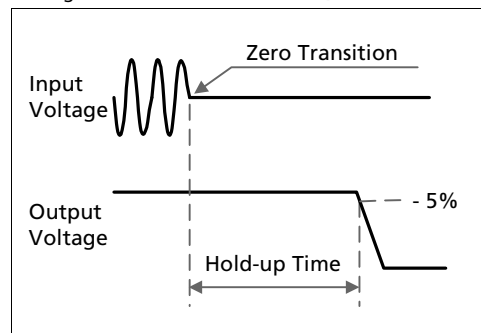

Fig. 7-2 Shut-down behavior, definitions



### 8. DC-OK RELAY CONTACT

This feature monitors the output voltage, which is produced by the power supply itself. It is independent of a back-fed voltage from a unit connected in parallel to the power supply output.

|                   |   |                                  |                       |
|-------------------|---|----------------------------------|-----------------------|
| Contact closes    | As soon as the output voltage reaches the adjusted output voltage level.  |                                  |                       |
| Contact opens     | As soon as the output voltage dips more than 10% below the adjusted output voltage. Short dips will be extended to a signal length of 250ms. Dips shorter than 1ms will be ignored. |                                  |                       |
| Contact re-closes | As soon as the output voltage exceeds 90% of the adjusted voltage.  |                                  |                       |
| Contact ratings   | max   | 60Vdc 0.3A, 30Vdc 1A, 30Vac 0.5A | resistive load        |
|                   | min   | 1mA at 5Vdc                      | min. permissible load |
| Isolation voltage | See dielectric strength table in section 18.  |                                  |                       |

Fig. 8-1 DC-ok relay contact behavior

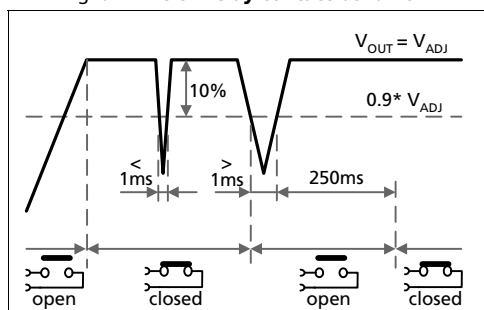

**Note:** The DC-ok feature requires that the output voltage reaches the nominal (=adjusted) level after turn-on in order to function according to specification. If this level cannot be achieved, the overload lamp will be on and the DC-ok contact will be open. The overload signal will only shut off as soon as the adjusted voltage is reached. This is an important condition to consider particularly, if the load is a battery, the power supply is used in parallel or the power supply is used for N+1 redundant systems.



### 9. EFFICIENCY AND POWER LOSSES

|                       |      | AC 100V | AC 120V | AC 230V |  |
|-----------------------|------|---------|---------|---------|--|
| Efficiency            | typ. | 91.7%   | 92.5%   | 94.0%   | at 36V, 13.3A  |
| Average efficiency *) | typ. | 91.6%   | 92.3%   | 93.3%   | 25% at 3.8A, 25% at 6.7A, 25% at 10.5A, 25% at 13.3A |
| Power losses          | typ. | 9.0W    | 9.2W    | 10.0W   | at 36V, 0A   |
|                       | typ. | 43.4W   | 38.9W   | 30.6W   | at 36V, 13.3A  |

\*) The average efficiency is an assumption for a typical application where the power supply is loaded with 25% of the nominal load for 25% of the time, 50% of the nominal load for another 25% of the time, 75% of the nominal load for another 25% of the time and with 100% of the nominal load for the rest of the time.

Fig. 9-1 Efficiency vs. output current at 36V, typ

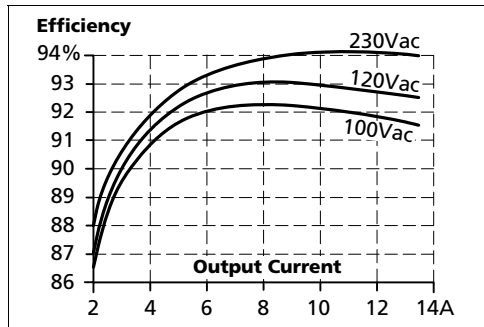

Fig. 9-2 Losses vs. output current at 36V, typ.

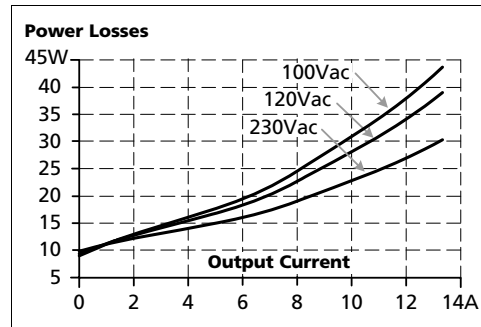

Fig. 9-3 Efficiency vs. input voltage at 36V, 13.3A, typ.

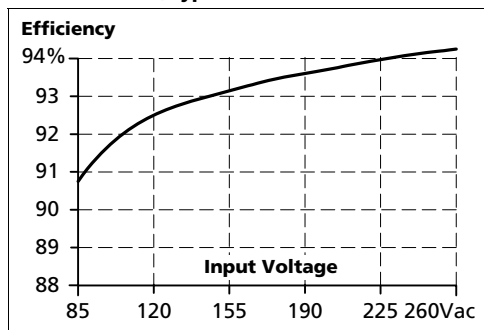
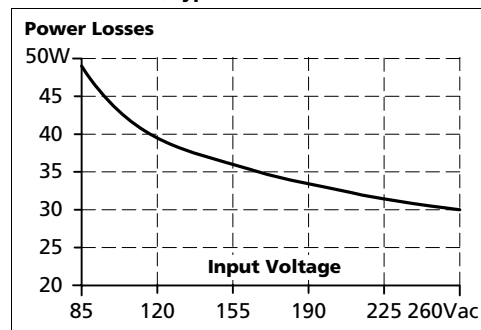

Fig. 9-4 Losses vs. input voltage at 36V, 13.3A, typ.



### 10. LIFETIME EXPECTANCY AND MTBF

|                              | AC 100V     | AC 120V     | AC 230V     |   |
|------------------------------|-------------|-------------|-------------|---|
| Lifetime expectancy *)       | 53 000h     | 61 000h     | 84 000h     | at 36V, 13.3A and 40°C                        |
|                              | 118 000h    | 127 000h    | 146 000h    | at 36V, 6.7A and 40°C                         |
|                              | 149 000h *) | 171 000h *) | 236 000h *) | at 36V, 13.3A and 25°C                        |
| MTBF **) SN 29500, IEC 61709 | 407 000h    | 441 000h    | 469 000h    | at 36V, 13.3A and 40°C                        |
|                              | 749 000h    | 799 000h    | 840 000h    | at 36V, 13.3A and 25°C                        |
| MTBF **) MIL HDBK 217F       | 204 000h    | 215 000h    | 229 000h    | at 36V, 13.3A and 40°C;<br>Ground Benign GB40 |
|                              | 273 000h    | 288 000h    | 308 000h    | at 36V, 13.3A and 25°C;<br>Ground Benign GB25 |

- \*) The **Lifetime expectancy** shown in the table indicates the minimum operating hours (service life) and is determined by the lifetime expectancy of the built-in electrolytic capacitors. Lifetime expectancy is specified in operational hours and is calculated according to the capacitor's manufacturer specification. The manufacturer of the electrolytic capacitors only guarantees a maximum life of up to 15 years (131 400h). Any number exceeding this value is a calculated theoretical lifetime which can be used to compare devices.
- \*\*) **MTBF** stands for **Mean Time Between Failure**, which is calculated according to statistical device failures, and indicates reliability of a device. It is the statistical representation of the likelihood of a unit to fail and does not necessarily represent the life of a product. The MTBF figure is a statistical representation of the likelihood of a device to fail. A MTBF figure of e.g. 1 000 000h means that statistically one unit will fail every 100 hours if 10 000 units are installed in the field. However, it can not be determined if the failed unit has been running for 50 000h or only for 100h.

### 11. FUNCTIONAL DIAGRAM

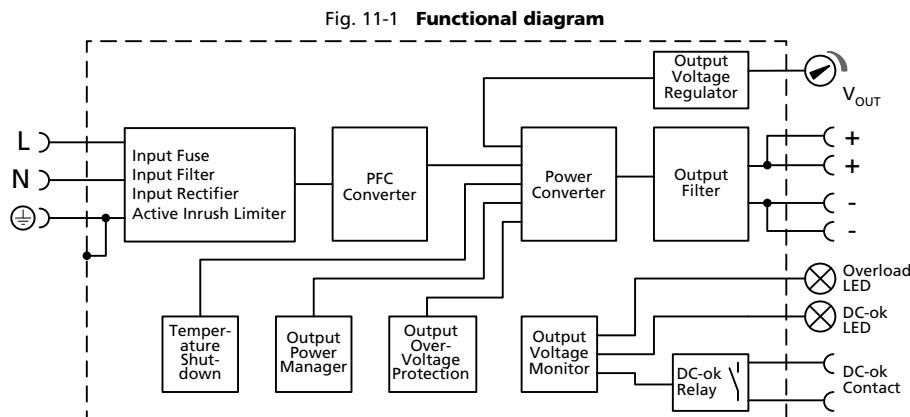

## 12. TERMINALS AND WIRING

Bi-stable, quick-connect spring clamp terminals. Shipped in open position.  
 - IP20 Finger safe construction.  
 - Suitable for field- and factory installation.

| Type                                    | Input                  | Output                 | DC-OK-Signal           |
|---|------------------------|------------------------|------------------------|
|   | spring-clamp terminals | spring-clamp terminals | spring-clamp terminals |
| Solid wire                              | 0.5-6mm <sup>2</sup>   | 0.5-6mm <sup>2</sup>   | 0.3-4mm <sup>2</sup>   |
| Stranded wire                           | 0.5-4mm <sup>2</sup>   | 0.5-4mm <sup>2</sup>   | 0.3-2.5mm <sup>2</sup> |
| American Wire Gauge                     | 20-10 AWG              | 20-10 AWG              | 26-12 AWG              |
| Wire stripping length                   | 10mm / 0.4inch         | 10mm / 0.4inch         | 6mm / 0.25inch         |
| Max. wire diameter (including ferrules) | 2.8mm                  | 2.8mm                  | 2.25mm                 |

### Instructions:

- Use appropriate copper cables that are designed for minimum operating temperatures of:  
 60°C for ambient up to 45°C and  
 75°C for ambient up to 60°C minimum  
 90°C for ambient up to 70°C minimum.
- Follow national installation codes and installation regulations!
- Ensure that all strands of a stranded wire enter the terminal connection!
- Do not use the unit without PE connection.
- Unused terminal compartments should be securely tightened.
- Ferrules are allowed.

Fig. 12-1 Connecting a wire

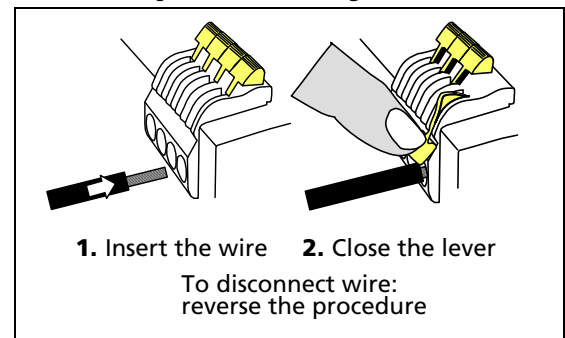

### Daisy Chaining of Outputs:

Daisy chaining (jumping from one power supply output to the next) is allowed as long as the average output current through one terminal pin does not exceed 25A. If the current is higher, use a separate distribution terminal block as shown in Fig. 12-3.

Fig. 12-2 Daisy chaining of outputs

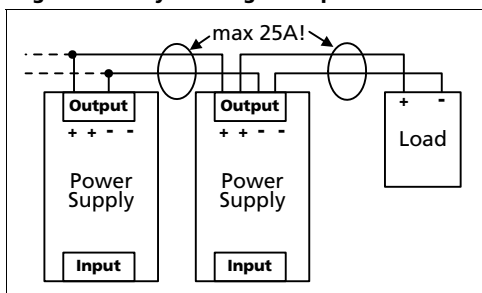
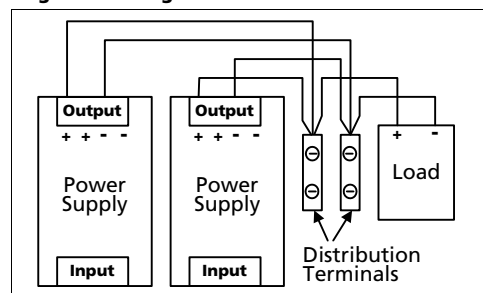

Fig. 12-3 Using distribution terminals



### 13. FRONT SIDE AND USER ELEMENTS

Fig. 13-1 Front side



**A Input Terminals** (Quick-connect spring-clamp terminals)

- N, L** Line input
- PE (Protective Earth) input

**B Output Terminals** (Quick-connect spring-clamp terminals, two pins per pole)

- +** Positive output
- Negative (return) output

**C DC-OK Relay Contact** (Quick-connect spring-clamp terminals)

The DC-OK relay contact is synchronized with the DC-OK LED. See chapter 8 for details.

**D Output voltage potentiometer**

Open the flap to adjust the output voltage. Factory set: 36.0V

**E DC-OK LED** (green)

On, when the output voltage is >90% of the adjusted output voltage

**F Overload LED** (red)

On, when the voltage on the output terminals is <90% of the adjusted output voltage, or in case of a short circuit in the output. Input voltage is required.

#### Indicators, LEDs

|                               | Overload LED | DC-OK LED | DC-OK Contact |
|-------------------------------|--------------|-----------|---------------|
| Normal mode                   | OFF          | ON        | Closed        |
| During BonusPower®            | OFF          | ON        | Closed        |
| Overload ( $V_{OUT} < 90\%$ ) | *)           | OFF       | Open          |
| Output short circuit          | *)           | OFF       | Open          |
| Temperature Shut-down         | *)           | OFF       | Open          |
| No input power                | OFF          | OFF       | Open          |

\*) Up to 4s of overloading, the power supply delivers continuous output current. After this, the output power is reduced to nearly zero for approx. 17s before a new start attempt is automatically performed. If the overload has been cleared, the device will operate normally. If the overload still exists, the output current will be delivered for 2 to 4s (depending on the overload) again followed by a 17s rest time. This cycle is repeated as long as the overload exists.

The red overload LED is permanently on when the overload current is continuously flowing. During the 17s rest period, the red LED is flashing with a frequency of approx. 1.3Hz.

### 14. EMC

The power supply is suitable for applications in industrial environment as well as in residential, commercial and light industry environment without any restrictions. A detailed EMC report is available on request.

| <b>EMC Immunity</b>      |               | According generic standards: EN 61000-6-1 and EN 61000-6-2  |   |  |
|--------------------------|---------------|---|---|--|
| Electrostatic discharge  | EN 61000-4-2  | contact discharge<br>air discharge  | 8kV<br>15kV   | Criterion A<br>Criterion A   |
| Electromagnetic RF field | EN 61000-4-3  | 80MHz-2.7GHz  | 10V/m   | Criterion A  |
| Fast transients (Burst)  | EN 61000-4-4  | input lines<br>output lines<br>DC-OK signal (coupling clamp)  | 4kV<br>2kV<br>1kV   | Criterion A<br>Criterion A<br>Criterion A  |
| Surge voltage on input   | EN 61000-4-5  | L → N<br>L → PE, N → PE   | 2kV<br>4kV  | Criterion A<br>Criterion A   |
| Surge voltage on output  | EN 61000-4-5  | + → -<br>+ / - → PE   | 1kV<br>1kV  | Criterion A<br>Criterion A   |
| Surge voltage on DC-OK   | EN 61000-4-5  | DC-OK signal → PE   | 1kV   | Criterion A  |
| Conducted disturbance    | EN 61000-4-6  | 0.15-80MHz  | 10V   | Criterion A  |
| Mains voltage dips       | EN 61000-4-11 | 0% of 100Vac<br>40% of 100Vac<br>70% of 100Vac<br>0% of 200Vac<br>40% of 200Vac<br>70% of 200Vac                                    | 0Vac, 20ms<br>40Vac, 200ms<br>70Vac, 500ms<br>0Vac, 20ms<br>80Vac, 200ms<br>140Vac, 500ms | Criterion A<br>Criterion C<br>Criterion A<br>Criterion A<br>Criterion A<br>Criterion A |
| Voltage interruptions    | EN 61000-4-11 | 0% of 200Vac (=0V)  | 5000ms  | Criterion C  |
| Voltage sags             | SEMI F47 0706 | dips on the input voltage according to SEMI F47 standard<br>80% of 120Vac (96Vac)<br>70% of 120Vac (84Vac)<br>50% of 120Vac (60Vac) | 1000ms<br>500ms<br>200ms  | Criterion A<br>Criterion A<br>Criterion A  |
| Powerful transients      | VDE 0160      | over entire load range  | 750V, 1.3ms   | Criterion C  |

**Criteria:**

- A:** Power supply shows normal operation behavior within the defined limits.
- C:** Temporary loss of function is possible. Power supply may shut-down and restarts by itself. No damage or hazards for the power supply will occur.

| <b>EMC Emission</b>                 |   | According generic standards: EN 61000-6-3 and EN 61000-6-4        |  |
|-------------------------------------|---|---|--|
| Conducted emission input lines      | EN 55011, EN 55022, FCC Part 15, CISPR 11, CISPR 22 | Class B   |  |
| Conducted emission output lines **) | IEC/CISPR 16-1-2, IEC/CISPR 16-2-1                  | limits for DC power port acc. EN 61000-6-3 are not fulfilled ***) |  |
| Radiated emission                   | EN 55011, EN 55022                                  | Class B   |  |
| Harmonic input current              | EN 61000-3-2  | fulfilled for class A equipment                                   |  |
| Voltage fluctuations, flicker       | EN 61000-3-3  | fulfilled *)  |  |

This device complies with FCC Part 15 rules.

Operation is subjected to following two conditions: (1) this device may not cause harmful interference, and (2) this device must accept any interference received, including interference that may cause undesired operation.

- \*) tested with constant current loads, non pulsing
- \*\*) for information only, not mandatory for EN 61000-6-3
- \*\*\*) Quasi-peak values fulfilled, average values +5dB

|                              |   |   |
|------------------------------|---|---|
| <b>Switching Frequencies</b> | The power supply has four converters with four different switching frequencies included. One is nearly constant. The others are input voltage and load dependent. |   |
| Switching frequency 1        | 100kHz  | Resonant converter, nearly constant               |
| Switching frequency 2        | 110kHz to 500kHz  | Boost converter, input voltage and load dependent |
| Switching frequency 3        | 73kHz to 114kHz   | PFC converter, input voltage and load dependent   |
| Switching frequency 4        | 35kHz to 45kHz  | Aux. converter, input voltage and load dependent  |

## 15. ENVIRONMENT

|                            |  |  |
|----------------------------|--|--|
| Operational temperature *) | -25°C to +70°C (-13°F to 158°F)  | reduce output power according Fig. 15-1                                      |
| Storage temperature        | -40 to +85°C (-40°F to 185°F)  | for storage and transportation   |
| Output de-rating           | 12W/°C   | 60-70°C (140°F to 158°F)   |
| Humidity **)               | 5 to 95% r.H.  | IEC 60068-2-30   |
| Vibration sinusoidal       | 2-17.8Hz: ±1.6mm; 17.8-500Hz: 2g<br>2 hours / axis   | IEC 60068-2-6  |
| Shock                      | 15g 6ms, 10g 11ms  | IEC 60068-2-27, DIN-rail mounting  |
|                            | 3 bumps / direction, 18 bumps in total   |  |
|                            | 30g 6ms, 20g 11ms  |  |
| Altitude                   | 0 to 2000m (0 to 6 560ft)  | without any restrictions   |
|                            | 2000 to 6000m (6 560 to 20 000ft)  | reduce output power or ambient temperature, see Fig. 15-2                    |
| Altitude de-rating         | 30W/1000m or 5°C/1000m   | IEC 62103, EN 50178, overvoltage category II > 2000m (6500ft), see Fig. 15-2 |
| Over-voltage category      | III  | IEC 62103, EN 50178, altitudes up to 2000m                                   |
|                            | II   | altitudes from 2000m to 6000m  |
| Degree of pollution        | 2  | IEC 62103, EN 50178, not conductive  |
| LABS compatibility         | The unit does not release any silicone or other LABS-critical substances and is suitable for use in paint shops. |  |

\*) Operational temperature is the same as the ambient temperature and is defined as the air temperature 2cm below the unit.  
 \*\*) Do not energize while condensation is present

Fig. 15-1 Output current vs. ambient temp.

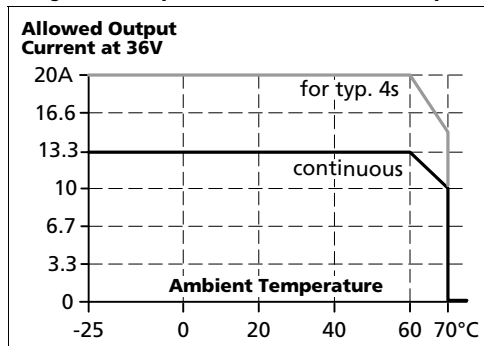
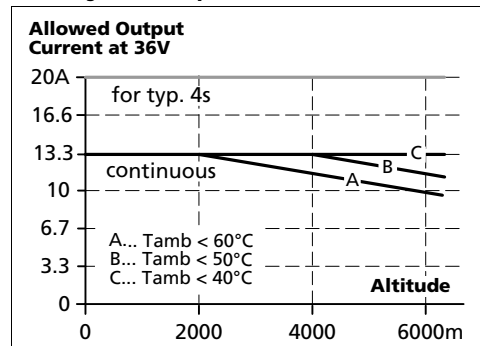

Fig. 15-2 Output current vs. altitude



### 16. PROTECTION FEATURES

|                                |  |   |
|--------------------------------|--|---|
| Output protection              | Electronically protected against overload, no-load and short-circuits *) |   |
| Output over-voltage protection | typ. 50Vdc<br>max. 54Vdc   | In case of an internal power supply defect, a redundant circuit limits the maximum output voltage. The output shuts down and automatically attempts to restart. |
| Degree of protection           | IP 20  | EN/IEC 60529  |
| Penetration protection         | > 3.5mm / > 5mm  | top side / bottom side; e.g. screws, small parts  |
| Over-temperature protection    | yes  | Output shut-down with automatic restart   |
| Input transient protection     | MOV (Metal Oxide Varistor)   |   |
| Internal input fuse            | included   | not user replaceable  |

\*) In case of a protection event, audible noise may occur.

### 17. SAFETY FEATURES

|                                 |   |  |
|---------------------------------|---|--|
| Input / output separation *)    | SELV<br>PELV<br>double or reinforced insulation   | IEC/EN 60950-1<br>IEC/EN 60204-1, EN 50178, IEC 62103, IEC 60364-4-41  |
| Class of protection             | I   | PE (Protective Earth) connection required  |
| Isolation resistance            | > 5M $\Omega$   | input to output, 500Vdc  |
| PE resistance                   | < 0.1 $\Omega$  |  |
| Touch current (leakage current) | typ. 0.23mA / 0.63mA<br>typ. 0.34mA / 0.93mA<br>typ. 0.58mA / 1.56mA<br>< 0.31mA / 0.77mA<br>< 0.45mA / 1.13mA<br>< 0.80mA / 2.00mA | 100Vac, 50Hz, TN-,TT-mains / IT-mains<br>120Vac, 60Hz, TN-,TT-mains / IT-mains<br>230Vac, 50Hz, TN-,TT-mains / IT-mains<br>110Vac, 50Hz, TN-,TT-mains / IT-mains<br>132Vac, 60Hz, TN-,TT-mains / IT-mains<br>264Vac, 50Hz, TN-,TT-mains / IT-mains |

\*) double or reinforced insulation

### 18. DIELECTRIC STRENGTH

The output voltage is floating and has no ohmic connection to the ground. Type and factory tests are conducted by the manufacturer. Field tests may be conducted in the field using the appropriate test equipment which applies the voltage with a slow ramp (2s up and 2s down). Connect all input-terminals together as well as all output poles before conducting the test. When testing, set the cut-off current settings to the value in the table below.

Fig. 18-1 Dielectric strength

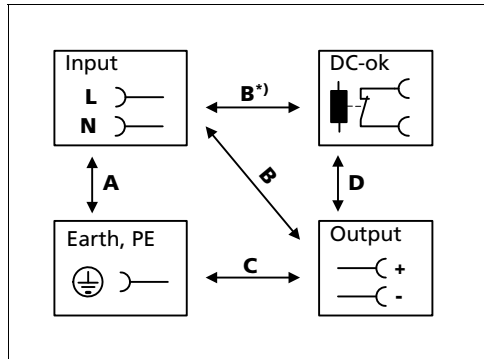

|                         |     | <b>A</b> | <b>B</b> | <b>C</b> | <b>D</b> |
|-------------------------|-----|----------|----------|----------|----------|
| Type test               | 60s | 2500Vac  | 3000Vac  | 500Vac   | 500Vac   |
| Factory test            | 5s  | 2500Vac  | 2500Vac  | 500Vac   | 500Vac   |
| Field test              | 5s  | 2000Vac  | 2000Vac  | 500Vac   | 500Vac   |
| Cut-off current setting |     | > 15mA   | > 15mA   | > 40mA   | > 1mA    |

To fulfil the PELV requirements according to EN60204-1 § 6.4.1, we recommend that either the + pole, the - pole or any other part of the output circuit shall be connected to the protective earth system. This helps to avoid situations in which a load starts unexpectedly or can not be switched off when unnoticed earth faults occur.

B\*) When testing input to DC-OK ensure that the max. voltage between DC-OK and the output is not exceeded (column D). We recommend connecting DC-OK pins and the output pins together when performing the test.

### 19. APPROVALS

EC Declaration of Conformity



The CE mark indicates conformance with the  
 - EMC directive 2004/108/EC,  
 - Low-voltage directive (LVD) 2006/95/EC and  
 - RoHS directive 2011/65/EU

IEC 60950-1  
2<sup>nd</sup> Edition



CB Scheme,  
Information Technology Equipment

UL 508



Listed for use as Industrial Control Equipment;  
U.S.A. (UL 508) and Canada (C22.2 No. 107-1-01);  
E-File: E198865

UL 60950-1  
2<sup>nd</sup> Edition



Recognized for use as Information Technology Equipment,  
Level 5; U.S.A. (UL 60950-1) and Canada (C22.2 No. 60950-1);  
E-File: E137006  
Applicable for altitudes up to 2000m.

ANSI / ISA 12.12.01-2007  
(Class I Div 2)



Recognized for use in Hazardous Location Class I Div 2 T3  
Groups A,B,C,D systems; U.S.A. (ANSI / ISA 12.12.01-2007) and  
Canada (C22.2 No. 213-M1987)

Marine



GL (Germanischer Lloyd) classified and  
ABS (American Bureau for Shipping) PDA  
Environmental category: C, EMC2  
Marine and offshore applications

GOST P



Certificate of Conformity for Russia and other GUS countries



### 20. PHYSICAL DIMENSIONS AND WEIGHT

|                         |  |
|-------------------------|--|
| Weight                  | 1200g / 2.65lb   |
| DIN-Rail                | Use 35mm DIN-rails according to EN 60715 or EN 50022 with a height of 7.5 or 15mm. The DIN-rail height must be added to the unit depth (127mm) to calculate the total required installation depth. |
| Installation Clearances | See chapter 2  |

Fig. 20-1 **Front view**

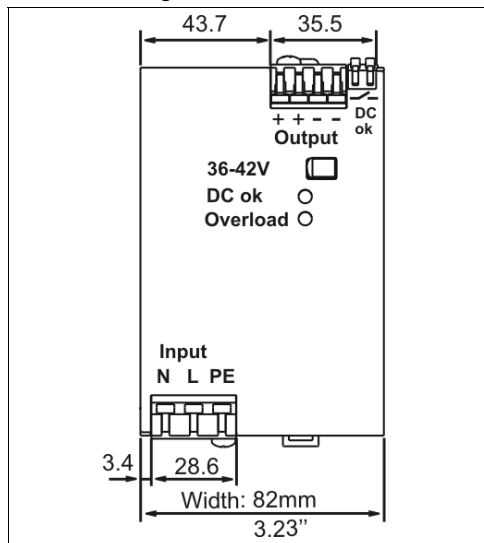
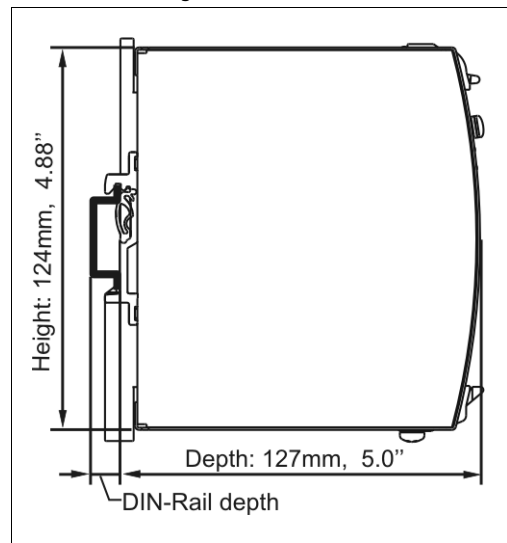

Fig. 20-2 **Side view**



## 21. ACCESSORIES

### 21.1. ZM2.WALL WALL MOUNTING BRACKET

This bracket is used to mount the power supply onto a flat surface without utilizing a DIN-Rail.

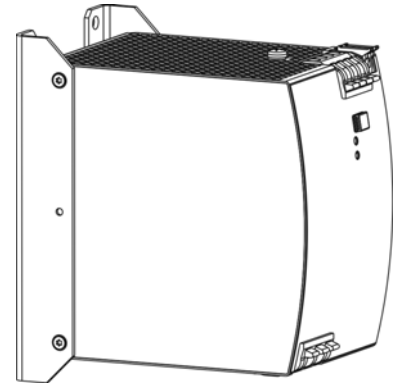
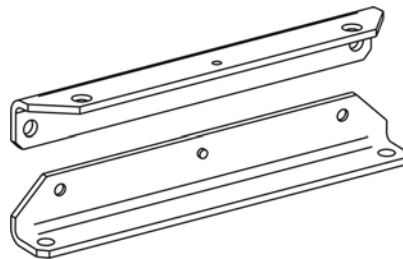

### 21.2. ZM15.SIDE SIDE MOUNTING BRACKET

This bracket is used to mount Dimension units sideways with or without utilizing a DIN-Rail. The two aluminum brackets and the black plastic slider of the unit have to be detached, so that the steel brackets can be mounted.

For sideways DIN-rail mounting, the removed aluminum brackets and the black plastic slider need to be mounted on the steel bracket.

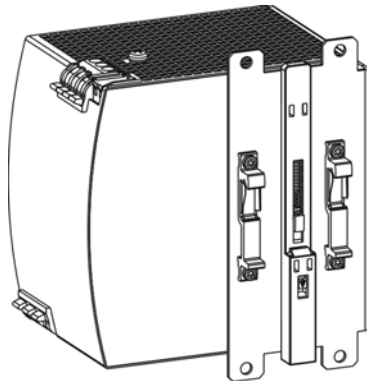

Side mounting with DIN-rail brackets

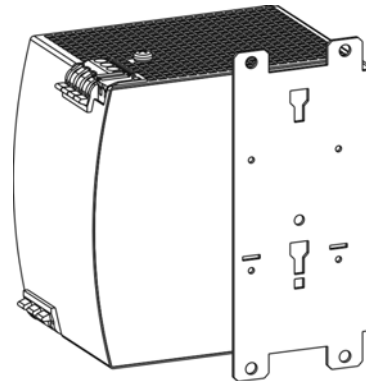

Side mounting without DIN-rail brackets

### 21.3. YR40.482 REDUNDANCY MODULES

**YR40.482** – (2x 20A Inputs, 1x 40A output)



The YR40.482 is equipped with two input channels, which are individually decoupled by utilizing mosfet technology. Using mosfets instead of diodes reduces the heat generation and the voltage drop between input and output. The YR40.482 does not require an additional auxiliary voltage and is self-powered even in case of a short circuit across the output. Due to the low power losses, the unit is very slender and only requires 46mm width on the DIN-rail.

Fig. 21-1 **Typical 1+1 Redundant configuration for 48V, 10A with a dual redundancy module**

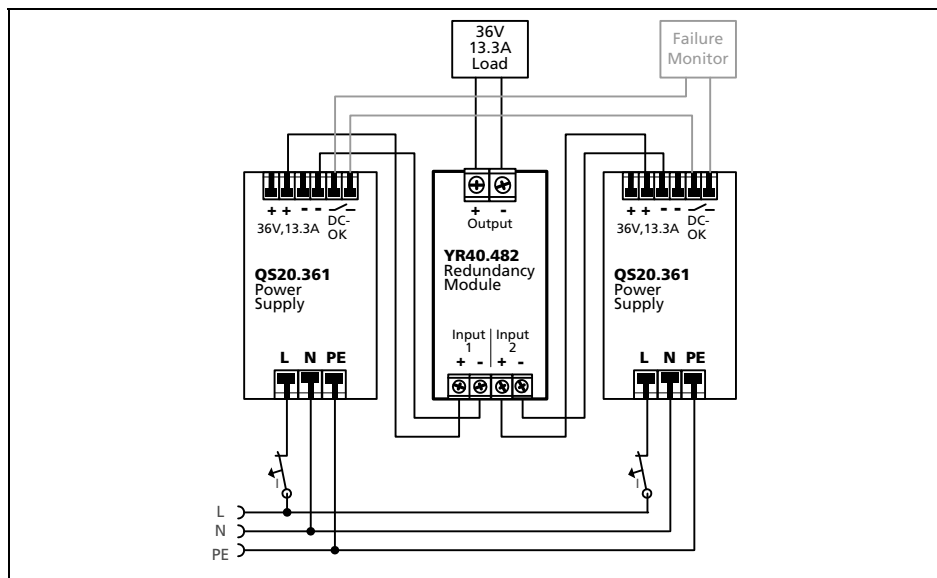

## 22. APPLICATION NOTES

### 22.1. REPETITIVE PULSE LOADING

Typically, a load current is not constant and varies over time. This power supply is designed to support loads with a higher short-term power demand (=BonusPower®). The short-term duration is hardware controlled by an output power manager and is available on a repeated basis. If the BonusPower® load lasts longer than the hardware controller allows it, the output voltage will dip and the next BonusPower® is available after the BonusPower® recovery time (see chapter 6) has elapsed.

To avoid this, the following rules must be met:

- The power demand of the pulse must be below 150% of the nominal output power.
- The duration of the pulse power must be shorter than the allowed BonusPower® time. (see output section)
- The average (R.M.S.) output current must be below the specified continuous output current. If the R.M.S. current is higher, the unit will respond with a thermal shut-down after a period of time. Use the maximum duty cycle curve (Fig. 22-2) to check if the average output current is below the nominal current.

Fig. 22-1 Repetitive pulse loads, definitions

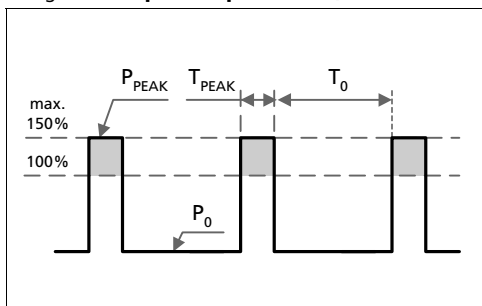

- P<sub>0</sub>** Base load (W)
- P<sub>PEAK</sub>** Pulse load (above 100%)
- T<sub>0</sub>** Duration between pulses (s)
- T<sub>PEAK</sub>** Pulse duration (s)

Fig. 22-2 Max. duty cycle curve

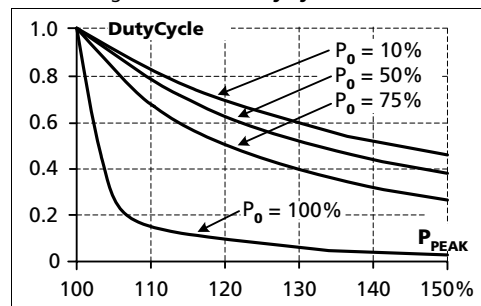

$$\text{DutyCycle} = \frac{T_{\text{peak}}}{T_{\text{peak}} + T_0}$$

$$T_0 = \frac{T_{\text{peak}} - (\text{DutyCycle} \times T_{\text{peak}})}{\text{DutyCycle}}$$

**Example:** A load is powered continuously with 240W (= 50% of the rated output load). From time to time a peak power of 720W (= 150% of the rated output load) is needed for 1 second.

The question is: How often can this pulse be supplied without overloading the power supply?

- Make a vertical line at P<sub>PEAK</sub> = 150% and a horizontal line where the vertical line crosses the P<sub>0</sub> = 50% curve. Read the max. duty cycle from the duty cycle-axis (= 0.37)
- Calculate the required pause (base load) length T<sub>0</sub>:
- Result: The required pause length = 1.7s
- Max. repetition rate = pulse +pause length = **2.7s**

$$T_0 = \frac{T_{\text{peak}} - (\text{DutyCycle} \times T_{\text{peak}})}{\text{DutyCycle}} = \frac{1\text{s} - (0.37 \times 1\text{s})}{0.37} = \mathbf{1.7\text{s}}$$

#### More examples for pulse load compatibility:

| P <sub>PEAK</sub> | P <sub>0</sub> | T <sub>PEAK</sub> | T <sub>0</sub> | P <sub>PEAK</sub> | P <sub>0</sub> | T <sub>PEAK</sub> | T <sub>0</sub> |
|-------------------|----------------|-------------------|----------------|-------------------|----------------|-------------------|----------------|
| 720W              | 480W           | 1s                | >25s           | 720W              | 240W           | 0.1s              | >0.16s         |
| 720W              | 0W             | 1s                | >1.3s          | 720W              | 240W           | 1s                | >1.6s          |
| 600W              | 240W           | 1s                | > 0.75s        | 720W              | 240W           | 3s                | >4.9s          |

### 22.2. PEAK CURRENT CAPABILITY

Solenoids, contactors and pneumatic modules often have a steady state coil and a pick-up coil. The inrush current demand of the pick-up coil is several times higher than the steady-state current and usually exceeds the nominal output current (including the PowerBoost). The same situation applies when starting a capacitive load.

Branch circuits are often protected with circuit breakers or fuses. In case of a short or an overload in the branch circuit, the fuse needs a certain amount of over-current to trip or to blow. The peak current capability ensures the safe operation of subsequent circuit breakers.

Assuming the input voltage is turned on before such an event, the built-in large sized output capacitors inside the power supply can deliver extra current. Discharging this capacitor causes a voltage dip on the output. The following two examples show typical voltage dips:

Fig. 22-3 Peak load with 2x the nominal current for 50ms, typ.

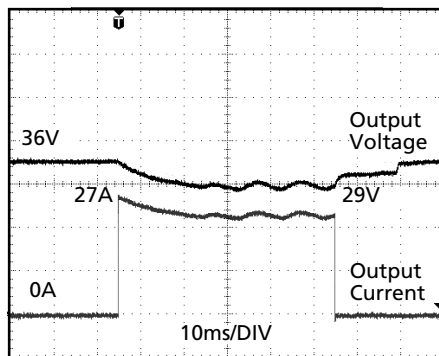

Peak load 27A (resistive) for 50ms  
Output voltage dips from 36V to 29V.

Fig. 22-4 Peak load with 5x the nominal current for 5ms, typ.

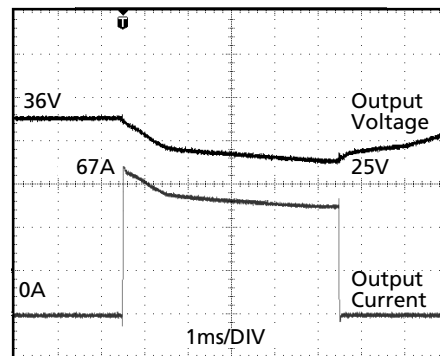

Peak load 67A (resistive) for 5ms  
Output voltage dips from 36V to 25V.

Please note: The DC-OK relay triggers when the voltage dips more than 10% for longer than 1ms.

### 22.3. BACK-FEEDING LOADS

Loads such as decelerating motors and inductors can feed voltage back to the power supply. This feature is also called return voltage immunity or resistance against Back- E.M.F. (Electro Magnetic Force).

This power supply is resistant and does not show malfunctioning when a load feeds back voltage to the power supply. It does not matter whether the power supply is on or off.

The maximum allowed feed-back-voltage is 48Vdc. The absorbing energy can be calculated according to the built-in large sized output capacitor which is specified in chapter 6.

### 22.4. EXTERNAL INPUT PROTECTION

The unit is tested and approved for branch circuits up to 20A. An external protection is only required if the supplying branch has an ampacity greater than this. Check also local codes and local requirements. In some countries local regulations might apply.

If an external fuse is necessary or utilized, minimum requirements need to be considered to avoid nuisance tripping of the circuit breaker. A minimum value of 10A B- or C-Characteristic breaker should be used

### 22.5. CHARGING OF BATTERIES

The power supply can be used to charge lead-acid or maintenance free batteries. (Three 12V batteries in series)

**Instructions for charging batteries:**

- a) Set output voltage (measured at no load and at the battery end of the cable) very precisely to the end-of-charge voltage.
- b) Use a 20A circuit breaker (or blocking diode) between the power supply and the battery.
- c) Ensure that the output current of the power supply is below the allowed charging current of the battery.
- d) Use only matched batteries when putting 12V types in series.
- e) The return current to the power supply (battery discharge current) is typ. 9mA when the power supply is switched off (except in case a blocking diode is utilized).

|                       |       |       |       |       |
|-----------------------|-------|-------|-------|-------|
| End-of-charge voltage | 41.7V | 41.3V | 40.7V | 40.2V |
| Battery temperature   | 10°C  | 20°C  | 30°C  | 40°C  |

### 22.6. OUTPUT CIRCUIT BREAKERS

Standard miniature circuit breakers (MCB's or UL1077 circuit breakers) are commonly used for AC-supply systems and may also be used on 36V branches.

MCB's are designed to protect wires and circuits. If the ampere value and the characteristics of the MCB are adapted to the wire size that is used, the wiring is considered as thermally safe regardless of whether the MCB opens or not.

To avoid voltage dips and under-voltage situations in adjacent 24V branches which are supplied by the same source, a fast (magnetic) tripping of the MCB is desired. A quick shutdown within 10ms is necessary corresponding roughly to the ride-through time of PLC's. This requires power supplies with high current reserves and large output capacitors. Furthermore, the impedance of the faulty branch must be sufficiently small in order for the current to actually flow. The best current reserve in the power supply does not help if Ohm's law does not permit current flow. The following table has typical test results showing which B- and C-Characteristic MCBs magnetically trip depending on the wire cross section and wire length.

Fig. 22-5 Test circuit

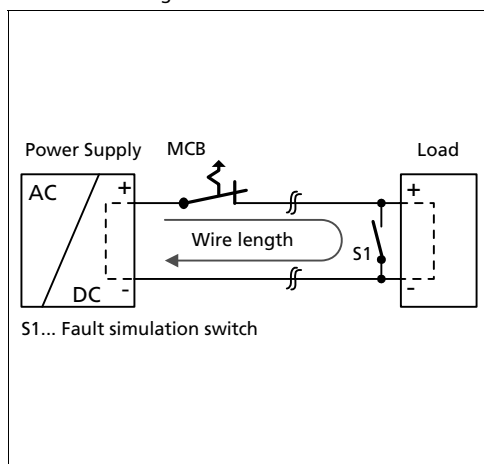

Maximal wire length\*) for a fast (magnetic) tripping:

|              | 0.75mm <sup>2</sup> | 1.0mm <sup>2</sup> | 1.5mm <sup>2</sup> | 2.5mm <sup>2</sup> |
|--------------|---------------------|--------------------|--------------------|--------------------|
| <b>C-2A</b>  | 51m                 | 68m                | 92m                | 152m               |
| <b>C-3A</b>  | 36m                 | 51m                | 71m                | 112m               |
| <b>C-4A</b>  | 26m                 | 33m                | 49m                | 77m                |
| <b>C-6A</b>  | 13m                 | 17m                | 19m                | 39m                |
| <b>C-8A</b>  | 5m                  | 7m                 | 10m                | 15m                |
| <b>C-10A</b> | 4m                  | 5m                 | 8m                 | 11m                |
| <b>C-13A</b> | 1m                  | 2m                 | 3m                 | 4m                 |
| <b>B-6A</b>  | 25m                 | 30m                | 46m                | 71m                |
| <b>B-10A</b> | 11m                 | 15m                | 19m                | 35m                |
| <b>B-13A</b> | 7m                  | 12m                | 16m                | 26m                |
| <b>B-16A</b> | -                   | 1m                 | 2m                 | 3m                 |

\*) Don't forget to consider twice the distance to the load (or cable length) when calculating the total wire length (+ and - wire).

### 22.7. PARALLEL USE TO INCREASE OUTPUT POWER

Power supplies from the same series (Q-Series) can be paralleled to increase the output power. The output voltage shall be adjusted to the same value ( $\pm 100\text{mV}$ ) with the same load conditions on all units, or the units can be left with the factory settings.

If more than three units are connected in parallel, a fuse or circuit breaker with a rating of 16A or 20A is required on each output. Alternatively, a diode or redundancy module can also be utilized.

Keep an installation clearance of 15mm (left / right) between two power supplies and avoid installing the power supplies on top of each other. Do not use power supplies in parallel in mounting orientations other than the standard mounting orientation (input terminals on bottom and output terminals on the top of the unit) or in any other condition where a derating of the output current is required (e.g. altitude, above 60°C, ...).

Pay attention that leakage current, EMI, inrush current, harmonics will increase when using multiple power supplies.

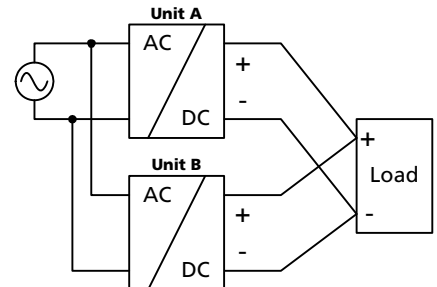

### 22.8. PARALLEL USE FOR REDUNDANCY

Power supplies can be paralleled for redundancy to gain higher system availability. Redundant systems require a certain amount of extra power to support the load in case one power supply unit fails. The simplest way is to put two power supplies in parallel. This is called a 1+1 redundancy. In case one power supply unit fails, the other one is automatically able to support the load current without any interruption. Redundant systems for a higher power demand are usually built in a N+1 method. E.g. five power supplies, each rated for 13.3A are paralleled to build a 50A redundant system. For N+1 redundancy the same restrictions apply as for increasing the output power, see also section 22.7.

**Please note:** This simple way to build a redundant system does not cover failures such as an internal short circuit in the secondary side of the power supply. In such a case, the defective unit becomes a load for the other power supplies and the output voltage can not be maintained any more. This can be avoided by utilizing decoupling diodes, which are included in the redundancy module YR40.482.

Recommendations for building redundant power systems:

- Use separate input fuses for each power supply.
- Monitor the individual power supply units. Therefore, use the DC-OK relay contact of the QS20 power supply.
- It is desirable to set the output voltages of all units to the same value ( $\pm 100\text{mV}$ ) or leave it at the factory setting.

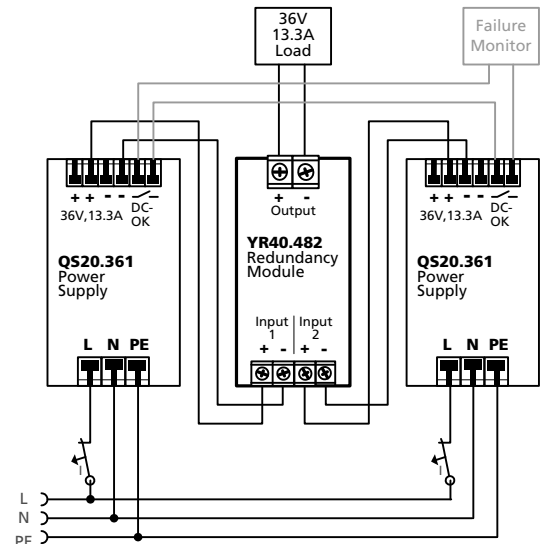

### 22.9. SERIES OPERATION

Power supplies of the same type can be connected in series for higher output voltages. It is possible to connect as many units in series as needed, providing the sum of the output voltage does not exceed 150Vdc. Voltages with a potential above 60Vdc are not SELV any more and can be dangerous. Such voltages must be installed with a protection against touching.

Earthing of the output is required when the sum of the output voltage is above 60Vdc.

Avoid return voltage (e.g. from a decelerating motor or battery) which is applied to the output terminals.

Keep an installation clearance of 15mm (left / right) between two power supplies and avoid installing the power supplies on top of each other. Do not use power supplies in series in mounting orientations other than the standard mounting orientation (input terminals on bottom and output terminals on the top of the unit).

Pay attention that leakage current, EMI, inrush current, harmonics will increase when using multiple power supplies.

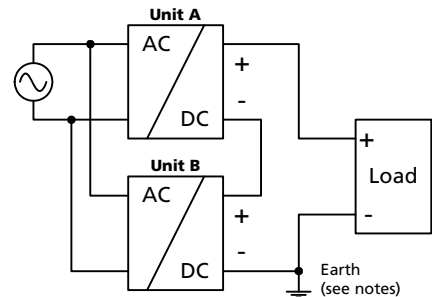

### 22.10. INDUCTIVE AND CAPACITIVE LOADS

The unit is designed to supply any kind of loads, including unlimited capacitive and inductive loads.

### 22.11. OPERATION ON TWO PHASES

The power supply can also be used on two-phases of a three-phase-system. Such a phase-to-phase connection is allowed as long as the supplying voltage is below 240V<sup>+15%</sup>. Use a fuse or a circuit breaker to protect the N input. The N input is internally not protected and is in this case connected to a hot wire. Appropriate fuses or circuit breakers are specified in section 22.4 "External Input Protection".

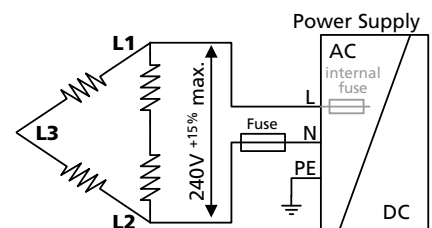

### 22.12. USE IN A TIGHTLY SEALED ENCLOSURE

When the power supply is installed in a tightly sealed enclosure, the temperature inside the enclosure will be higher than outside. In such situations, the inside temperature defines the ambient temperature for the power supply.

The following measurement results can be used as a reference to estimate the temperature rise inside the enclosure.

The power supply is placed in the middle of the box, no other heat producing items are inside the box

|                                |   |
|--------------------------------|---|
| Enclosure:                     | Rittal Typ IP66 Box PK 9522 100, plastic, 254x180x165mm                             |
| Load:                          | 36V, 10.6A; (=80%) load is placed outside the box                                   |
| Input:                         | 230Vac  |
| Temperature inside enclosure:  | 49.0°C (in the middle of the right side of the power supply with a distance of 2cm) |
| Temperature outside enclosure: | 24.3°C  |
| Temperature rise:              | 24.7K   |



### 22.13. MOUNTING ORIENTATIONS

Mounting orientations other than input terminals on the bottom and output on the top require a reduction in continuous output power or a limitation in the maximum allowed ambient temperature. The amount of reduction influences the lifetime expectancy of the power supply. Therefore, two different derating curves for continuous operation can be found below:

**Curve A1** Recommended output current.

**Curve A2** Max allowed output current (results in approximately half the lifetime expectancy of A1).

Fig. 22-6  
**Mounting Orientation A**  
(Standard orientation)

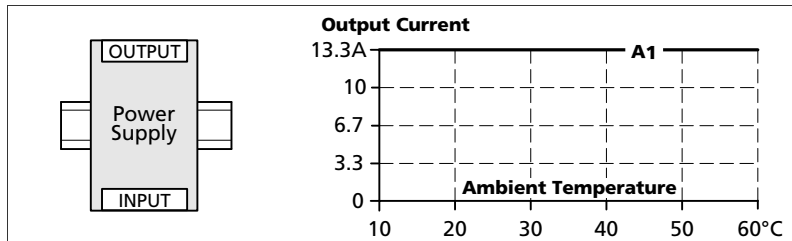

Fig. 22-7  
**Mounting Orientation B**  
(Upside down)

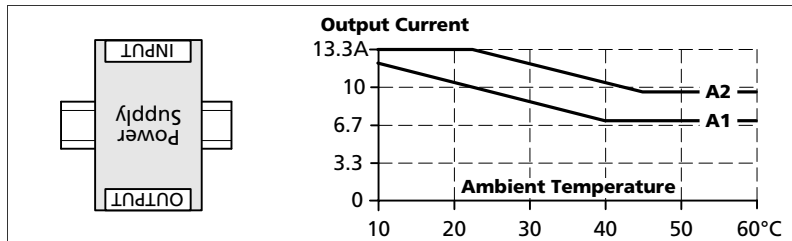

Fig. 22-8  
**Mounting Orientation C**  
(Table-top mounting)

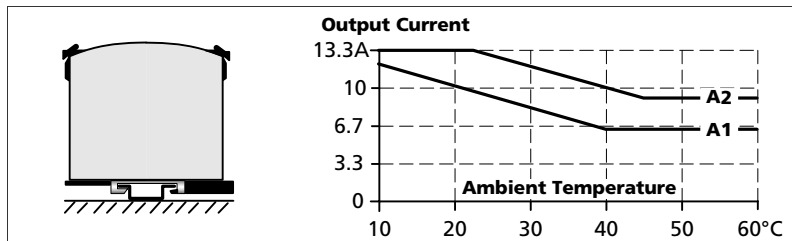

Fig. 22-9  
**Mounting Orientation D**  
(Horizontal cw)

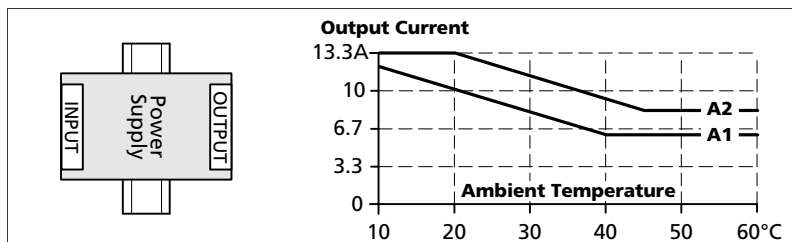

Fig. 22-10  
**Mounting Orientation E**  
(Horizontal ccw)

